

# Form F11

(April 2023)



The **ACT**<sup>®</sup>

2022 | 2023

---

In response to your request for Test Information Release materials, this booklet contains the test questions, scoring keys, and conversion tables used in determining your ACT scores. Enclosed with this booklet is a report that lists each of your answers, shows whether your answer was correct, and, if your answer was not correct, gives the correct answer.

## Directions

This booklet contains tests in English, mathematics, reading, and science. These tests measure skills and abilities highly related to high school course work and success in college. **Calculators may be used on the mathematics test only.**

The questions in each test are numbered, and the suggested answers for each question are lettered. On the answer document, the rows of ovals are numbered to match the questions, and the ovals in each row are lettered to correspond to the suggested answers.

For each question, first decide which answer is best. Next, locate on the answer document the row of ovals numbered the same as the question. Then, locate the oval in that row lettered the same as your answer. Finally, fill in the oval completely. Use a soft lead pencil and make your marks heavy and black. **Do not use ink or a mechanical pencil.**

Mark only one answer to each question. If you change your mind about an answer, erase your first mark thoroughly before marking your new answer. For each question, make certain that you mark in the row of ovals with the same number as the question.

Only responses marked on your answer document will be scored. Your score on each test will be based only on the number of questions you answer correctly during the time allowed for that test. You will **not** be penalized for guessing. **It is to your advantage to answer every question even if you must guess.**

You may work on each test **only** when the testing staff tells you to do so. If you finish a test before time is called for that test, you should use the time remaining to reconsider questions you are uncertain about in that test. You may **not** look back to a test on which time has already been called, and you may **not** go ahead to another test. To do so will disqualify you from the examination.

Lay your pencil down immediately when time is called at the end of each test. You may **not** for any reason fill in or alter ovals for a test after time is called for that test. To do so will disqualify you from the examination.

Do not fold or tear the pages of your test booklet.

**DO NOT OPEN THIS BOOKLET  
UNTIL TOLD TO DO SO.**



## ENGLISH TEST

45 Minutes—75 Questions

**DIRECTIONS:** In the five passages that follow, certain words and phrases are underlined and numbered. In the right-hand column, you will find alternatives for the underlined part. In most cases, you are to choose the one that best expresses the idea, makes the statement appropriate for standard written English, or is worded most consistently with the style and tone of the passage as a whole. If you think the original version is best, choose “NO CHANGE.” In some cases, you will find in the right-hand column a question about the underlined part. You are to choose the best answer to the question.

You will also find questions about a section of the passage, or about the passage as a whole. These questions do not refer to an underlined portion of the passage, but rather are identified by a number or numbers in a box.

For each question, choose the alternative you consider best and fill in the corresponding oval on your answer document. Read each passage through once before you begin to answer the questions that accompany it. For many of the questions, you must read several sentences beyond the question to determine the answer. Be sure that you have read far enough ahead each time you choose an alternative.

## PASSAGE I

## Revenge and the Tour de France

Every July, bicyclists competing in the Tour de France speed more than 2,100 miles through the French countryside. They climb torturous mountain roads and rush downhill at speeds exceeding seventy miles per hour. Although testing strength, skill, and endurance,<sup>1</sup> was part of the original plan for the Tour, the main motive behind creating the race was a grudge.

In 1899, the editor of France’s more large sports newspaper, *Le Vélo*, had<sup>2</sup> wrote an article criticizing the wealthy industrialist Albert de Dion. De Dion, who had been an advertiser in *Le Vélo*, retaliated<sup>3</sup> by starting his own sports newspaper, *L’Auto*. He aimed to outsell *Le Vélo* and put it out of<sup>4</sup> business; therefore, *L’Auto* didn’t sell.

1. A. NO CHANGE  
B. testing strength, skill, and, endurance,  
C. testing strength, skill, and endurance  
D. testing, strength, skill and endurance
2. F. NO CHANGE  
G. most large sports newspaper, *Le Vélo*,  
H. largest sports newspaper, *Le Vélo*, had  
J. largest sports newspaper, *Le Vélo*,
3. A. NO CHANGE  
B. *Le Vélo*—retaliated  
C. *Le Vélo* retaliated,  
D. *Le Vélo* retaliated
4. F. NO CHANGE  
G. furthermore,  
H. however,  
J. indeed,



At the time, sports newspapers sponsored their own bicycle  races and reported on them to boost sales.

In this tradition, de Dion's editor proposed that *L'Auto* stage its own race. To make it distinctive, the race would be more difficult and longer than any before. It would be a  challenging race that started in Paris—a tour of France. The hope was that people would buy the paper each day to follow the action.

Leading up to the first Tour, *L'Auto* offered:  20,000 francs in prize money. The

winner would get 3,000  francs; the rest of the money would be shared among the other top finishers. Soon sixty cyclists had signed up.

The first inaugural Tour started on July 1, 1903.

It took eighteen  days and covered 1,508 miles, starting and  ending in Paris. Of the sixty cyclists, only twenty-one

completed the course. 12 For the race's end, thousands of spectators lined the streets of Paris to watch Maurice Garin cross the finish line first.

5. A. NO CHANGE  
B. races which  
C. races that  
D. races,
6. F. NO CHANGE  
G. On the other hand,  
H. In spite of this,  
J. In other words,
7. Given that all the choices are accurate, which one makes clearest that the Tour de France was designed to include a large part of France?  
A. NO CHANGE  
B. circle through all of the nation's major cities—  
C. be an outdoor race in several long stages—  
D. draw a lot of attention to *L'Auto*—
8. F. NO CHANGE  
G. offered: 20,000 francs,  
H. offered 20,000 francs,  
J. offered 20,000 francs
9. Which of the following alternatives to the underlined portion would NOT be acceptable?  
A. francs while the  
B. francs, and the  
C. francs, the  
D. francs. The
10. F. NO CHANGE  
G. Beginning on July 1, 1903, the first Tour commenced.  
H. On July 1, 1903, the initial Tour began its first run.  
J. The inaugural Tour began on July 1, 1903.
11. A. NO CHANGE  
B. days, and covered 1,508 miles, starting and ending,  
C. days, and covered 1,508 miles, starting, and ending  
D. days and covered 1,508 miles starting and ending
12. The writer is considering deleting the preceding sentence. Should the sentence be kept or deleted?  
F. Kept, because it reveals the number of cyclists who participated in the first Tour de France.  
G. Kept, because it provides a detail that suggests the difficulty of the first Tour de France.  
H. Deleted, because it repeats information found earlier in the essay.  
J. Deleted, because it doesn't pertain to the paragraph's focus on the first Tour de France.

*L'Auto* rushed out a special edition to cover the race's finish, because it sold over 130,000 copies. The popularity <sup>13</sup> of the Tour de France ensured the success of *L'Auto* and fabricated the demise of *Le Vélo*, which had gone out <sup>14</sup> of business by 1904. De Dion had his revenge, and a world-famous race was born.

13. A. NO CHANGE  
 B. unless  
 C. since  
 D. and
14. F. NO CHANGE  
 G. brought about  
 H. mustered up  
 J. inspired

Question 15 asks about the preceding passage as a whole.

15. Suppose the writer's primary purpose had been to summarize the founding of a famous race. Would this essay accomplish that purpose?
- A. Yes, because it gives the history of how *Le Vélo* sponsored the first Tour de France.  
 B. Yes, because it tells the story of de Dion and his role in creating the Tour de France.  
 C. No, because it instead focuses on de Dion's reasons for putting *Le Vélo* out of business.  
 D. No, because it doesn't discuss any of the competitors in the first Tour de France except Maurice Garin.

## PASSAGE II

### Alice Paul and the Nineteenth Amendment

Soon after arriving in England in 1907 to study social work, New Jersey-born suffragist and political activist Alice Paul joined the movement of Emmeline Pankhurst, being a vocal British suffragist. Paul admired <sup>16</sup> Pankhurst's direct, action-oriented approach, who raised <sup>17</sup> public and legislative interest in women's voting rights.

16. F. NO CHANGE  
 G. Pankhurst, in that she was  
 H. Pankhurst; there she was  
 J. Pankhurst,
17. A. NO CHANGE  
 B. which had raised  
 C. also raising  
 D. to raise



The campaign for women’s suffrage in the United States—relying in recent years on <sup>18</sup> polite appeals by

letter—while largely ignored. Upon her return home in <sup>19</sup> 1910, Paul sought to reshape the American campaign.

Paul became a member of the National American Woman Suffrage Association (NAWSA), she hoped to energize that organization. She was <sup>20</sup> soon angered by NAWSA’s support of President

Woodrow Wilson, whom remained near <sup>21</sup> silent about women’s right to vote. Paul left the group and formed the National Woman’s Party. The NWP was co-founded by someone Paul had met in London <sup>22</sup> when both were arrested during a suffrage demonstration. <sup>22</sup> On January 11, 1917, Paul and several other women

marched in front of the White House, waved banners <sup>23</sup> and shouting, boldly making clear their belief that since

women, half of the population, could not vote; <sup>24</sup> the United States was not a true democracy.

18. Given that all the following phrases are accurate, which one, if added here, would most clearly add new information to the writer’s characterization of the ineffectiveness of the US women’s suffrage campaign?

- F. writing tactfully to others for their cause and
- G. focusing on women’s suffrage through
- H. small, subdued gatherings and
- J. an approach that included

19. A. NO CHANGE  
B. had been  
C. that was  
D. and

20. F. NO CHANGE  
G. it was hoped by her  
H. her hope was  
J. hoping

21. A. NO CHANGE  
B. whom remained nearly  
C. who remained nearly  
D. who remained near

22. Given that all the choices are accurate, which one would provide the best transition to the rest of the paragraph?

- F. NO CHANGE
- G. held the president directly responsible for the ongoing disenfranchisement of women.
- H. was originally named the Congressional Union and wasn’t called the NWP until 1916.
- J. published a weekly journal, *The Suffragist*, to communicate with its members.

23. A. NO CHANGE  
B. were waving  
C. have waved  
D. waving

24. F. NO CHANGE  
G. vote—  
H. vote,  
J. vote



[1] For months, the protesters marched seven hours a day, five days a week—and their numbers grew. [2] Rather than pay a fine, many of the women, including Paul, chose time in a cold, unsanitary jail. [3] At first, the president conceded and tipped his hat to them as his car passed<sup>25</sup> through the White House gate, but six months later he

had them arrested for obstructing traffic. 26

Under public pressure, Wilson pardoned the prisoners. Still, the women’s protest and imprisonment, as Paul had hoped, significantly<sup>27</sup> raised public sympathy for the suffragists’ cause.

Wilson decided, finally, in a historic move,<sup>28</sup> to reverse his

stance, and endorse the suffrage amendment introduced in Congress in 1878. In 1919 Congress passed the Nineteenth

Amendment, and by 1920 women in the United States had the right to vote.<sup>30</sup>

25. Which choice makes it most clear that Wilson’s action of tipping his hat was meant to belittle the protestors?
- A. NO CHANGE  
 B. condescendingly  
 C. cordially  
 D. lightly
26. Which of the following sequences of sentences makes this paragraph most logical?
- F. NO CHANGE  
 G. 2, 1, 3  
 H. 3, 2, 1  
 J. 1, 3, 2
27. A. NO CHANGE  
 B. imprisonment. As Paul had hoped, significantly  
 C. imprisonment, as Paul had hoped. Significantly  
 D. imprisonment as Paul had hoped, significantly
28. Which choice most effectively emphasizes that a long period of time passed between the introduction of the suffrage amendment in Congress and Wilson’s endorsement of the amendment?
- F. NO CHANGE  
 G. rightfully, to the relief of the suffragists,  
 H. given the circumstances,  
 J. grudgingly,
29. A. NO CHANGE  
 B. stance, and endorse the suffrage amendment,  
 C. stance, and endorse, the suffrage amendment,  
 D. stance and endorse the suffrage amendment
30. Given that all the choices are accurate, which one most effectively concludes the paragraph and the essay by emphasizing the central result of Paul’s work?
- F. NO CHANGE  
 G. and today it is used by people both young and old as an example of one of the most significant constitutional conflicts in history.  
 H. despite the fact that it almost failed to pass in Congress by a single vote in the House of Representatives.  
 J. and Alice Paul worked for other human rights causes until her death in 1977 in New Jersey.



## PASSAGE III

## Life at Emiquon

Near Springfield, Illinois,  
and about 165 miles southwest of Chicago,  
<sup>31</sup>  
 egrets dive into still water, minks run through tall

bluestem grasses, and on waxy lily pads frogs sit.  
<sup>32</sup>

The habitat of these animals, an expanse of algae-rich  
<sup>33</sup>  
 marshes and shallow lakes on the floodplain of

the Illinois River, did not exist a few years ago.  
<sup>34</sup>  
 But endless rows of corn have become Emiquon

Preserve, one of the largest and most successful  
<sup>35</sup>  
 wetlands restoration projects in the world.

In the 1920s, water began to be pumped from  
 this area, a vibrant wetland for thousands of years,  
 to make way for the development of a massive farm.  
 Levees were built to block runoff from the Illinois  
River and, nearby prairies and hardwood forests were  
<sup>36</sup>

cleared. Even so, having lost their habitat, the wildlife  
<sup>37</sup>  
 that had thrived in the wetlands and surrounding areas  
 disappeared.

31. Given that all the choices are accurate, which one introduces information that is most relevant to the focus of the essay as a whole?
- A. NO CHANGE  
 B. a city with an extensive agricultural—not to mention political—heritage,  
 C. at the former site of one of the largest commercial farms in the state,  
 D. and just outside the cities of Havana and Lewistown,
32. Which choice best maintains the word pattern used in the preceding two examples in this sentence?
- F. NO CHANGE  
 G. sitting on waxy lily pads are frogs.  
 H. frogs sit on waxy lily pads.  
 J. on waxy lily pads sit frogs.
33. A. NO CHANGE  
 B. extensive  
 C. expense  
 D. expand
34. F. NO CHANGE  
 G. River, something that  
 H. River, and it  
 J. River that
35. Which of the following alternatives to the underlined portion would NOT be acceptable?
- A. largest, and one of the most successful,  
 B. largest—and most successful—  
 C. largest and most successful,  
 D. largest, most successful
36. F. NO CHANGE  
 G. River, and nearby prairies  
 H. River and, nearby prairies,  
 J. River, and nearby prairies,
37. A. NO CHANGE  
 B. For example, having  
 C. However, having  
 D. Having





The Nature Conservancy, convinced that the area's wetland ecosystem could be restored, bought the 7,000-acre property in 2000. By gradually shutting off the water pumps and removing the levees, as the ecologists would allow the area to flood. The area's original water levels, they predicted; would return in about three years. And once the water returned, so would the plant and animal life.

Within two years, many native plants that had lain dormant for decades reappeared, and, today, cattails and American lotus flourishes in the shallows.

Ecologists had to intervene to reintroduce native fish, but within five years, several species were spawning in

the floodwaters. Above 200 species of birds, including wetland, prairie, and woodland dwellers, have returned to the muddy shoals.

A visitor to Emiquon might notice a popular bird-watching area is impermeable because of flooding,

or a walking trail is impassible due to thick mud. 44 The Nature Conservancy stresses that from now on, the shifting waters of the Illinois River and the activities of plants and

38. F. NO CHANGE  
G. thereby  
H. when  
J. DELETE the underlined portion.

39. A. NO CHANGE  
B. predicted,  
C. predicted. Those  
D. predicted that they

40. F. NO CHANGE  
G. has again flourished  
H. is flourishing  
J. flourish

41. Given that all the choices are accurate, which one most clearly suggests that restoring native fish at Emiquon was a more hands-on process than restoring native plants?  
A. NO CHANGE  
B. Human manipulation of the natural flow of water had caused native fish to disappear from the area,  
C. Biologists knew that the native fish that had been lost included walleye and red-spotted sunfish,  
D. Emiquon ecologists were aware that fish are highly sensitive to environmental change,

42. F. NO CHANGE  
G. More then  
H. Over  
J. Past

43. A. NO CHANGE  
B. insurmountable  
C. inaccessible  
D. impervious

44. If the writer were to delete the preceding sentence, the essay would primarily lose:  
F. an example of two problems at Emiquon that conservationists have not been able to remedy.  
G. a description of conditions that visitors to Emiquon will sometimes encounter.  
H. an overview of improvements that will be made at Emiquon for the sake of visitors' comfort.  
J. an explanation of the reasons Emiquon is a popular destination for bird watchers.



animals—not human interests—will be what shape these wetlands that have recently been reestablished, the Nature Conservancy asserts.

- 45. A. NO CHANGE
- B. wetlands, just reestablished, that were not restored for humans' business interests or recreation.
- C. newly reestablished wetlands.
- D. DELETE the underlined portion and end the sentence with a period.

PASSAGE IV

Walter Alvarez's Impact

[1]

While studying a canyon in Italy during the 1970s, a mystery caught the attention of geologist Walter Alvarez.

At the K-Pg boundary, a band of rock that marks the end

of the Cretaceous period and the start of the Paleogene, Alvarez recognized evidence of a large extinction. Fossils

of many species of *foraminifera* (single-celled marine organisms) was abounding in the Cretaceous rock layer;

however, in the Paleogene rock layer above, only one species remained. Alvarez later learned that the formation

of the Paleogene fossils correlated to the mass extinction that wiped out over 70 percent of plants and animals,

including the dinosaurs. [A]

[2]

Most geologists in the 1970s believed at the time that this mass extinction occurred

over millions of years. Alvarez thought the

foraminifera fossils pointed to a more rapid

extinction. They decided to test the clay between the Cretaceous and Paleogene

layers to determine how long it took to form.

- 46. F. NO CHANGE
- G. there was a mystery that geologist Walter Alvarez stumbled onto.
- H. certain rocks presented a mystery to geologist Walter Alvarez.
- J. geologist Walter Alvarez stumbled onto a mystery.

- 47. A. NO CHANGE
- B. period and the start of the Paleogene—
- C. period, and the start, of the Paleogene,
- D. period, and the start of the Paleogene

- 48. F. NO CHANGE
- G. has abounded
- H. abounded
- J. abounds

- 49. A. NO CHANGE
- B. that this mass extinction, according to the geologists,
- C. during that decade that this mass extinction
- D. that this mass extinction

- 50. F. NO CHANGE
- G. demonstrated
- H. suggested
- J. revealed

- 51. A. NO CHANGE
- B. He and his team
- C. They and him
- D. The group

They looked for iridium, a rare element in Earth's crust that can also fall from space in trace amounts <sup>52</sup>. The clay had an iridium level of nine parts per billion—six hundred times greater than that of the rock around it.

[3]

Alvarez thought that such a staggering amount <sup>53</sup> of iridium must have come from space. Luis Alvarez, <sup>53</sup> a Nobel scientist and Walter's father, joined his son in developing a hypothesis about the extinction and the iridium. [B] In 1980, Alvarez's team published its theory: a huge meteorite had slammed into <sup>54</sup>

Earth. The dust and ash thrown into the <sup>55</sup> atmosphere and blocking sunlight for months.

[4]

For years, Walter Alvarez futilely searched in vain for an impact crater <sup>56</sup> large enough to substantiate his theory. Then, in <sup>57</sup> 1990, geoscientist Alan Hildebrand found evidence of an ancient asteroid impact that had occurred near Texas. [C] This find led Hildebrand to two geophysicists who had <sup>58</sup> discovered the Chicxulub Crater, a ninety-two-mile-wide crater off the coast of Mexico. [D] The discovery encouraged Alvarez's theory. A meteorite caused <sup>59</sup> the K-Pg extinction.

52. At this point, the writer is considering adding the following accurate phrase:

as the atmosphere burns up meteors

Should the writer make this addition here?

- F. Yes, because it indicates the amount of iridium that falls to Earth from space.
- G. Yes, because it indicates the process by which iridium from space comes to Earth.
- H. No, because the essay makes clear that Alvarez thought the iridium came from Earth's crust.
- J. No, because it is unrelated to the paragraph's discussion of iridium.

53. Which choice most clearly emphasizes that Alvarez thought the amount of iridium in the clay was surprisingly high?

- A. NO CHANGE
- B. an amount of iridium at this level
- C. rock with this much iridium
- D. this amount of iridium

54. F. NO CHANGE

- G. theory: suggesting
- H. theory being that
- J. theory and saying

55. A. NO CHANGE

- B. Earth, throwing dust and ash
- C. Earth. Throwing dust and ash
- D. Earth; throwing dust and ash

56. F. NO CHANGE

- G. unsuccessfully searched in vain for an
- H. searched in vain for a large
- J. searched in vain for an

57. A. NO CHANGE

- B. For example,
- C. Furthermore,
- D. Thus,

58. F. NO CHANGE

- G. lead Hildebrand to two geophysicists whom
- H. led Hildebrand to two geophysicists whom
- J. lead Hildebrand to two geophysicists who

59. A. NO CHANGE

- B. validated
- C. approved
- D. preferred



Question 60 asks about the preceding passage as a whole.

60. The writer is considering adding the following sentence to the essay:

Subsequent tests showed that the Chicxulub Crater was of K-Pg age.

If the writer were to add this sentence, it would most logically be placed at:

- F. Point A in Paragraph 1.
- G. Point B in Paragraph 3.
- H. Point C in Paragraph 4.
- J. Point D in Paragraph 4.

PASSAGE V

**Circles of the Sand**

Aerial photos capture a mysterious phenomenon along Namibia’s arid coastline: thousands of round, bare, patches of sandy earth pockmark a sea of stubbly grasses. The cause of these patches (known as “fairy circles”) had always outfoxed the scientists. But in 2013, ecologist Norbert Jürgens presented a promising new theory.

Between 2006 and 2012, Jürgens traveled primarily from Hamburg, Germany. He consistently found moister soil within each circle than in the surrounding desert. His findings were exciting—most species have adapted to Namibia’s arid climate—but also easy to explain. With no plants to absorb it, rain that soaks into the sandy soil of the

circles have had a chance to accumulate below ground.

- 61. A. NO CHANGE  
B. round, bare patches of sandy earth,  
C. round, bare patches of sandy earth  
D. round bare patches of sandy earth,
- 62. F. NO CHANGE  
G. flummoxed scientists for a really long interval.  
H. been puzzling scientists since forever.  
J. long eluded scientists.
- 63. Given that all the choices are accurate, which one most effectively leads the reader into this paragraph?  
A. NO CHANGE  
B. coauthored several papers on African biodiversity.  
C. taught ecology at the University of Hamburg.  
D. studied more than 1,200 fairy circles.
- 64. The writer wants to emphasize why the moister soil that Jürgens found was exciting. Given that all the choices are accurate, which one best accomplishes that goal?  
F. NO CHANGE  
G. —Namibia’s coastal regions get some moisture from thick fogs off the ocean—  
H. —inland temperatures can vary from freezing to scorching each day—  
J. —water is scarce in this climate—
- 65. A. NO CHANGE  
B. have an opportunity  
C. has a chance  
D. are able



The mystery of the circles lies not in the extra moisture but in the lack of vegetation: *why* are the circles so bare?

Jürgens believes that sand termites are the answer.

He found that each circle has many insect species, only

66

sand termites inhabit every circle—even new ones where moisture hasn't yet collected. He concludes that the subterranean termites, which “swim” through the sandy soil eating plant roots, kill the plants to engineer mini-reservoirs. Then, in times of drought,

67

68

the extra moisture sustains the termites. According to Jürgens, in established circles the termites also eat the roots of bordering grasses, which explains why the circles grow larger over time.

69

Some scientists challenge Jürgens, arguing that his theory doesn't explain the circles' symmetry and even-spacing. But despite continued debate over the circles' origin, no one disputes they're positive affect on local wildlife. Without fairy circles, soil in this climate would be parched for much of the year. The circles' extra moisture that supports more than termites; the grasses bordering

70

71

each circle grow taller than other desert plants.

72

66. F. NO CHANGE  
G. Although each circle contains  
H. In each circle there are  
J. Each circle includes
67. A. NO CHANGE  
B. circle: and  
C. circle;  
D. circle
68. F. NO CHANGE  
G. roots and killing  
H. roots and kill  
J. roots, killing
69. Which of the following alternatives to the underlined portion would NOT be grammatically acceptable?  
A. it is this extra moisture that  
B. the extra moisture is what  
C. when this extra moisture  
D. this extra moisture
70. F. NO CHANGE  
G. they're positive effect  
H. their positive effect  
J. their positive affect
71. A. NO CHANGE  
B. moisture, which supports  
C. moisture, supporting  
D. moisture supports
72. F. NO CHANGE  
G. is able to grow  
H. has grown  
J. grows



Birds, mammals, and other insects also gather at  
fairy circles, feeding on either the perimeter grass

73

or each other. 74

73. A. NO CHANGE  
 B. circles where they congregate,  
 C. circles as well,  
 D. circles, too,
74. Which of the following statements, if added here, would most effectively conclude the essay?
- F. Namibia is home to parts of the Kalahari desert, which extends into South Africa and Botswana.  
 G. The circles are hidden oases, masquerading as bare patches of sand.  
 H. The circles are spread across 1,200 miles of this captivating desert.  
 J. Jürgens also found spiders, beetles, and ants in the circles.

Question 75 asks about the preceding passage as a whole.

75. Suppose the writer's primary purpose had been to discuss contradictory explanations for a natural phenomenon. Would this essay accomplish that purpose?
- A. Yes, because it describes Jürgens's theory and then discusses the weaknesses of his explanation.  
 B. Yes, because it discusses both Jürgens's theory and other scientists' theories about fairy circles.  
 C. No, because it focuses on fairy circles' ecological impact rather than on vying theories about them.  
 D. No, because it focuses on Jürgens's theory of fairy circles without giving an alternate explanation.

**END OF TEST 1**

**STOP! DO NOT TURN THE PAGE UNTIL TOLD TO DO SO.**



## MATHEMATICS TEST

60 Minutes—60 Questions

**DIRECTIONS:** Solve each problem, choose the correct answer, and then fill in the corresponding oval on your answer document.

Do not linger over problems that take too much time. Solve as many as you can; then return to the others in the time you have left for this test.

You are permitted to use a calculator on this test. You may use your calculator for any problems you choose,

but some of the problems may best be done without using a calculator.

Note: Unless otherwise stated, all of the following should be assumed.

1. Illustrative figures are NOT necessarily drawn to scale.
2. Geometric figures lie in a plane.
3. The word *line* indicates a straight line.
4. The word *average* indicates arithmetic mean.

1. Given  $4x - 9 = 6x - 15$  is true,  $x = ?$

- A. -12
- B. -3
- C.  $-\frac{12}{5}$
- D.  $\frac{12}{5}$
- E. 3

**DO YOUR FIGURING HERE.**

2. In the figure below, parallel lines  $m$  and  $n$  are cut by transversal line  $t$ , and 2 angle measures are given. What is the value of  $x$ ?

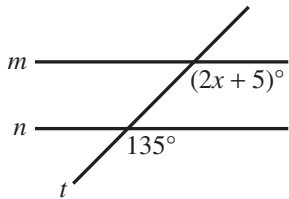

- F. 20
  - G. 25
  - H. 30
  - J. 65
  - K. 70
3. The 1st term in the geometric sequence below is  $-9$ . If it can be determined, what is the 6th term?
- $-9, 18, -36, 72, -144, \dots$
- A.  $-288$
  - B.  $-216$
  - C.  $216$
  - D.  $288$
  - E. Cannot be determined from the given information



4. A yogurt shop has 6 flavors of yogurt and 5 toppings. Each sundae consists of 1 yogurt flavor and 1 topping. Jaylen decided to surprise Takoda with a sundae, but he did not know her preferences. Given that Takoda has a preference of 1 flavor of yogurt and 1 topping from those available in the shop, what is the probability that Jaylen will choose the topping and yogurt that Takoda prefers?

- F.  $\frac{1}{30}$   
 G.  $\frac{1}{11}$   
 H.  $\frac{1}{6}$   
 J.  $\frac{1}{5}$   
 K.  $\frac{1}{4}$

5. How many *minutes* would it take a ship to travel 100 miles at a constant speed of 40 miles per hour?

- A. 24  
 B. 40  
 C. 60  
 D. 150  
 E. 250

6. A fan has 3 evenly spaced blades of negligible thickness, as shown below. What is the measure of an angle between 2 blades?

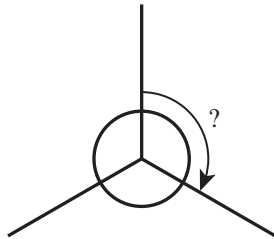

- F.  $30^\circ$   
 G.  $60^\circ$   
 H.  $90^\circ$   
 J.  $100^\circ$   
 K.  $120^\circ$

7.  $|6 - 5| - |3 - 7| = ?$

- A. -5  
 B. -3  
 C. 3  
 D. 5  
 E. 21

8. Which of the following values is the solution to the equation below?

$$\frac{2}{3}x + \frac{1}{4} = 8\frac{1}{4}$$

- F. 12  
 G.  $12\frac{3}{8}$   
 H.  $12\frac{3}{4}$   
 J. 36  
 K. 51

**DO YOUR FIGURING HERE.**





9. What is the volume, in cubic inches, of a sphere with a diameter of 10 inches?

(Note: The volume of a sphere,  $V$ , with radius  $r$  is given by the formula  $V = \frac{4}{3}\pi r^3$ .)

- A.  $\frac{60\pi}{3}$   
 B.  $\frac{100\pi}{3}$   
 C.  $\frac{400\pi}{3}$   
 D.  $\frac{500\pi}{3}$   
 E.  $\frac{4,000\pi}{3}$
10. A rhombus is a quadrilateral with all 4 sides of equal length. Three vertices of a rhombus are graphed in the standard  $(x,y)$  coordinate plane below.

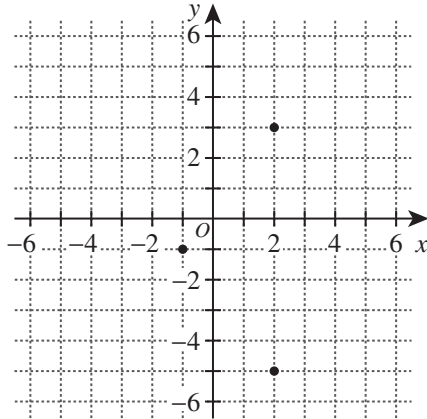

One of the following points is the location of the 4th vertex of this rhombus. Which one?

- F.  $(4, -1)$   
 G.  $(5, -4)$   
 H.  $(5, -1)$   
 J.  $(6, -2)$   
 K.  $(6, 0)$
11. For an architecture class project, Lizette is making a scale drawing of Mr. Patel's classroom, which is rectangular with a width of 25 feet and a length of 30 feet. Lizette draws a 3-inch line segment to represent the width of the rectangle. How long a line segment, in inches, should Lizette draw to represent the length of the rectangle?
- A.  $2\frac{1}{2}$   
 B. 3  
 C.  $3\frac{3}{5}$   
 D.  $4\frac{7}{12}$   
 E. 5

**DO YOUR FIGURING HERE.**



12. In the standard  $(x,y)$  coordinate plane, a line intersects the  $y$ -axis at  $(0,3)$  and contains the point  $(9,4)$ . What is the slope of the line?

F.  $\frac{1}{9}$   
 G.  $\frac{3}{5}$   
 H.  $\frac{2}{3}$   
 J.  $\frac{3}{2}$   
 K. 9

DO YOUR FIGURING HERE.

13. The equations of four  $(x,y)$  relations are given below.

I.  $5y = (x - 1)(x - 3)(x + 3)$

II.  $(x - 1)^2 + (y - 1)^2 = 9$

III.  $\frac{y}{4} = \sqrt{x + 4} - 1$

IV.  $y + 5 = \left(\frac{2}{5}\right)^x$

The graph in the standard  $(x,y)$  coordinate plane of each of these relations is shown below.

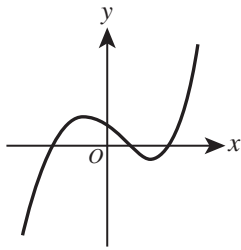

I

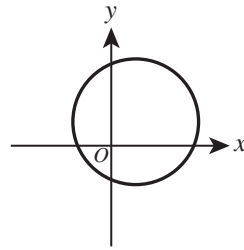

II

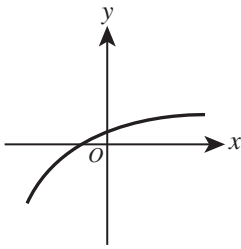

III

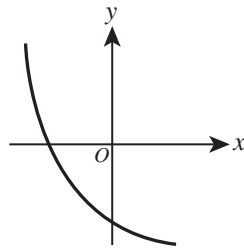

IV

Of these relations, which are functions?

- A. I only  
 B. I and III only  
 C. I and IV only  
 D. I, II, and III only  
 E. I, III, and IV only
14. If  $(x + k)^2 = x^2 + 88x + k^2$ , then  $k = ?$
- F. 44  
 G. 88  
 H. 176  
 J. 352  
 K. 704



15. Which of the following expressions is equal to

$$\frac{1}{3} + \frac{2}{9} + \frac{1}{10} ?$$

- A.  $\frac{1+2+1}{3+9+10}$   
 B.  $\frac{30+20+9}{90}$   
 C.  $\frac{1+2+1}{90}$   
 D.  $\frac{1 \times 2 \times 1}{3 \times 9 \times 10}$   
 E.  $\frac{1 \times 2 \times 1}{90}$

**DO YOUR FIGURING HERE.**

16. Each side of square  $ABCD$  has a length of 20 ft. A certain rectangle whose area is equal to the area of  $ABCD$  has a width of 10 ft. What is the length, in feet, of the rectangle?

- F. 10  
 G. 20  
 H. 30  
 J. 40  
 K. 50

17. In Amul's yard, there was no snow on the ground at 10:15 a.m. From 10:15 a.m. until 3:30 p.m., it snowed at an average rate of  $\frac{1}{2}$  inch per hour. How many inches of snow were on the ground at 3:30 p.m. ?

- A.  $1\frac{23}{40}$   
 B.  $1\frac{5}{8}$   
 C.  $1\frac{3}{4}$   
 D.  $2\frac{23}{40}$   
 E.  $2\frac{5}{8}$

18. On each of 8 tests, Gustav scored 2 points higher than Russ. When their average test scores on these 8 tests are compared, how many points higher is Gustav's average than Russ's average?

- F. 2  
 G. 4  
 H. 5  
 J. 6  
 K. 16



19. Each of 5 different data sets is summarized with its own boxplot below.

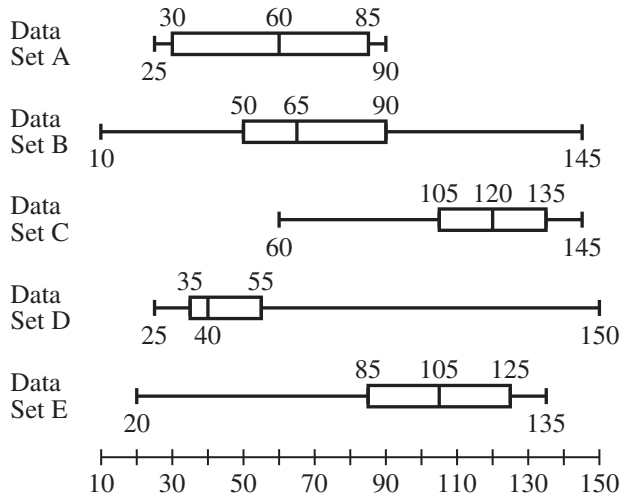

Which of these data sets has the greatest interquartile range?

- A. A  
 B. B  
 C. C  
 D. D  
 E. E
20. A surveyor is standing on ground that is level with the base of the cell phone tower shown below. From the point on the ground where the surveyor is standing, the angle of elevation to the top of the tower is  $40^\circ$ . The distance from the surveyor to the tower is 200 feet. Which of the following values is closest to the height, in feet, of the tower?

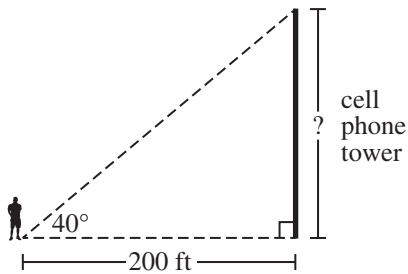

(Note:  $\sin 40^\circ \approx 0.64$ ,  $\cos 40^\circ \approx 0.77$ , and  $\tan 40^\circ \approx 0.84$ )

- F. 130  
 G. 155  
 H. 170  
 J. 240  
 K. 260
21. Given  $x + y = 30$  and  $x - y = 18$ , what is the value of  $y$ ?
- A. 6  
 B. 9  
 C. 12  
 D. 24  
 E. 48

DO YOUR FIGURING HERE.



22. Let  $m$  and  $n$  be positive numbers such that  $m < n$ . Which of the following expressions has the greatest value?

F.  $\frac{m+n}{m}$

G.  $\frac{m+n}{n}$

H.  $\frac{m+n}{m+n}$

J.  $\frac{m}{m+n}$

K.  $\frac{n}{m+n}$

**DO YOUR FIGURING HERE.**

23. The mean of 3 consecutive whole numbers is 30. What are the 3 numbers?

A. 9, 10, 11

B. 10, 11, 12

C. 28, 30, 32

D. 29, 30, 31

E. 89, 90, 91

24. Given that  $\sin A = \frac{24}{25}$ , which of the following values could  $\tan A$  equal?

F.  $\frac{1}{24}$

G.  $\frac{7}{24}$

H. 1

J.  $\frac{24}{7}$

K. 24

25. On the local car dealer's lot, there are only 25 cars with power windows and only 17 cars with heated seats. The number of cars on the lot with both power windows and heated seats *must* be:

A. exactly 42.

B. exactly 8.

C. at least 8.

D. no more than 8.

E. no more than 17.

26. To determine the number of fish in a pond, a biologist catches a random sample of 200 fish, tags them, and releases them back into the pond. A week later, the biologist catches a random sample of 120 fish from this pond, and 32 of them have tags. Which of the following is the best estimate of the number of fish in the pond?

F. 232

G. 320

H. 352

J. 750

K. 3,840



27. Isabelle divided a sum of money among 4 types of investments as shown in the pie chart below. Given that \$100 was invested into a savings account, what amount, to the nearest \$10, did she invest in equities?

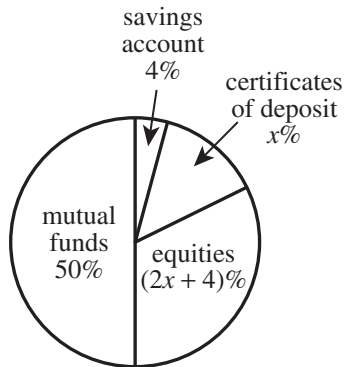

- A. \$ 130  
 B. \$ 530  
 C. \$ 800  
 D. \$1,250  
 E. \$1,280
28. A jar of solid-colored marbles contains some yellow marbles, 21 blue marbles, 40 red marbles, and 14 green marbles. The probability of randomly drawing a green marble is  $\frac{2}{15}$ . How many yellow marbles are in the jar?
- F. 10  
 G. 12  
 H. 25  
 J. 30  
 K. 68
29. Dai traveled to 3 locations during a workday. Dai remained at each location a whole number of hours. The graph below shows the relationship between time, in hours, into his workday and total distance, in miles, traveled. Which of the following values is closest to Dai's average speed, in miles per hour, for the parts of the workday when he was traveling?

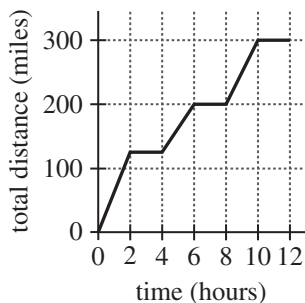

- A. 30  
 B. 38  
 C. 40  
 D. 50  
 E. 63

DO YOUR FIGURING HERE.



Use the following information to answer questions 30–33.

DO YOUR FIGURING HERE.

The chart below provides some facts about 4 planets in our solar system.

	Mercury	Venus	Earth	Mars
Average distance from the Sun (millions of miles)	36.0	67.2	93.0	141.6
Orbital period (Earth days)	88.0	224.7	365.3	687.0
Equatorial diameter (miles)	3,032	7,521	7,926	4,222
Strength of surface gravity compared to Earth (%)*	37.8	90.7	100.0	37.7
Average surface temperature (°Fahrenheit)	332.4°	867.0°	59.0°	−85.0°

\*The strength of surface gravity refers to the gravitational acceleration of an object near the surface of the planet. The values given are percents of  $32.2 \text{ ft/sec}^2$  (feet per second per second), which is the gravitational acceleration of an object near the surface of Earth.

30. What is the positive difference between the given values of average distance from the Sun for Mars and for Mercury?

- F. 10,560
- G. 105,600
- H. 10,560,000
- J. 105,600,000
- K. 1,056,000,000

31. According to the table, which of the following expressions is equal to the difference, in feet per second per second, between the gravitational acceleration of an object near the surface of Venus and the gravitational acceleration of an object near the surface of Mercury?

- A.  $0.378(32.2)$
- B.  $(0.907 - 0.378)(32.2)$
- C.  $(0.907 + 0.378)(32.2)$
- D.  $\frac{32.2}{0.907 - 0.378}$
- E.  $\frac{32.2}{0.907 + 0.378}$



32. For all the planets in the solar system, the equation  $T = 0.4D^{1.5}$  models the relationship between  $T$ , the orbital period in Earth days, and  $D$ , the average distance in millions of miles from the Sun, given in the table. According to this model, which of the following expressions is equal to Mercury's orbital period in Earth days?

- F.  $0.4(6^2)$
- G.  $0.4(6^3)$
- H.  $(0.4 \cdot 6)^3$
- J.  $0.4(\sqrt[3]{36})^2$
- K.  $(\sqrt[3]{0.4 \cdot 36})^2$

**DO YOUR FIGURING HERE.**

33. The formula  $C = \frac{5}{9}(F - 32)$  gives the conversion from  $F$  degrees Fahrenheit to  $C$  degrees Celsius. The formula  $K = C + 273$  gives the conversion from  $C$  degrees Celsius to  $K$  kelvins. To the nearest integer, what is the average surface temperature, in kelvins, of Mars?

- A. -117
- B. -65
- C. 87
- D. 188
- E. 208

34. At 12 midnight the center of a hurricane is 360 miles from the coast of Miami, as shown in the figure below. The hurricane has an approximate radius of 120 miles and is currently approaching the Miami area at 30 miles per hour. If the hurricane keeps its current conditions, what time, to the nearest hour, will the leading edge of the hurricane first reach Miami?

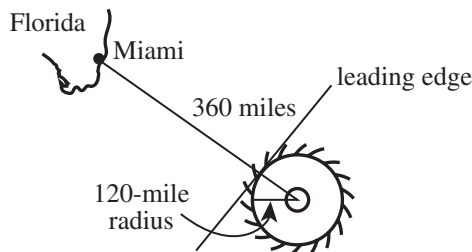

- F. 7 a.m.
- G. 8 a.m.
- H. 9 a.m.
- J. 10 a.m.
- K. 11 a.m.





35. The figure below is a section of a college basketball court. The square has sides that are 12 feet long, and 1 side of the square is a diameter of the circle. The shaded region is to be refinished at a cost of \$6.25 per square foot. The cost of the refinishing is closest to which of the following?

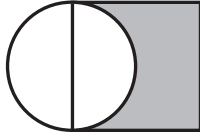

- A. \$195  
B. \$225  
C. \$550  
D. \$665  
E. \$675
36. Given that the equation  $\frac{3x-y}{x+y} = \frac{2}{4}$  is true, what is the value of  $\frac{x}{y}$  ?
- F.  $\frac{1}{5}$   
G.  $\frac{1}{2}$   
H.  $\frac{3}{5}$   
J.  $\frac{3}{2}$   
K. 3
37. Julia will serve grape juice from 12-ounce cans at her graduation party. She already has 3 boxes that each contain 12 such cans. How many more 12-ounce cans of grape juice does Julia need to have exactly enough juice to serve 60 guests 8 ounces each?
- A. 4  
B. 9  
C. 28  
D. 40  
E. 48
38. On a typical day at Limestone College,  $\frac{3}{5}$  of all students ride a bicycle to class. Among the rest of the students,  $\frac{1}{3}$  ride the bus and  $\frac{1}{6}$  walk. On a typical day, what fraction of the students ride the bus to class?
- F.  $\frac{1}{5}$   
G.  $\frac{2}{15}$   
H.  $\frac{1}{10}$   
J.  $\frac{1}{15}$   
K.  $\frac{1}{18}$

DO YOUR FIGURING HERE.



39. Vectors  $\mathbf{u}$  and  $\mathbf{v}$  are shown in standard position in the standard  $(x,y)$  coordinate plane below.

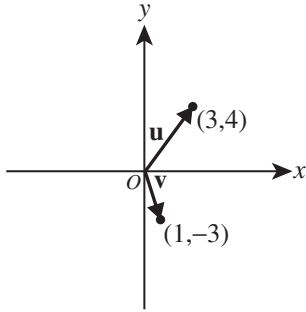

DO YOUR FIGURING HERE.

Which of the following vectors in standard position in the standard  $(x,y)$  coordinate plane is  $\mathbf{v} - \mathbf{u}$ ?

A.

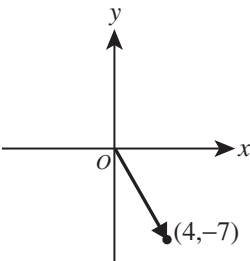

D.

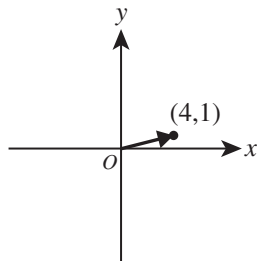

B.

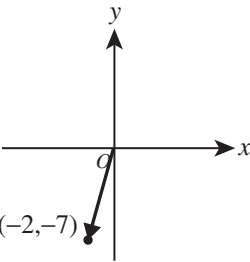

E.

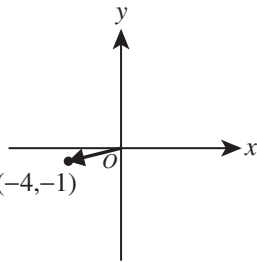

C.

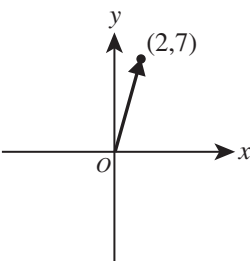

40. Suzi ran 3 laps on a circular path with a radius of 49 meters. Which of the following values is closest to the distance, in meters, that Suzi ran?

- F. 150
- G. 460
- H. 920
- J. 5,660
- K. 7,550



Use the following information to answer questions 41–43.

DO YOUR FIGURING HERE.

One thousand people registered to run a 5-mile road race. Each of the 1,000 people who registered paid either the early, regular, or late registration fee given in the table below.

Type of registration	Registration fee
Early	\$25.00
Regular	\$35.00
Late	\$45.00

Ninety percent of all the registered people started the race, and 95% of the people who started the race also finished the race.

41. There were 300 people who paid the early registration fee, 400 people who paid the regular fee, and 300 people who paid the late fee. What is the total revenue from entry fees, in dollars, written in scientific notation?
- A.  $2.15 \times 10^4$   
 B.  $3.50 \times 10^4$   
 C.  $21.50 \times 10^3$   
 D.  $35.00 \times 10^3$   
 E.  $350.00 \times 10^2$
42. Kirk ran the 1st  $x$  miles of the race at a rate of 7 minutes per mile and the rest of the race at a rate of 8 minutes per mile. One of the following expressions gives the total amount of minutes that it took Kirk to run the race. Which one?
- F.  $\frac{x}{7} + \frac{x-5}{8}$   
 G.  $\frac{x}{7} + \frac{5-x}{8}$   
 H.  $7x + 8x$   
 J.  $7x + 8(x - 5)$   
 K.  $7x + 8(5 - x)$
43. One registered person will be randomly selected to win a raffle prize. Which of the following expressions is equal to the probability that the selected person did NOT finish the race?
- A. 0.90  
 B.  $0.95(0.90)$   
 C.  $1 - 0.90$   
 D.  $1 - 0.95$   
 E.  $1 - 0.95(0.90)$

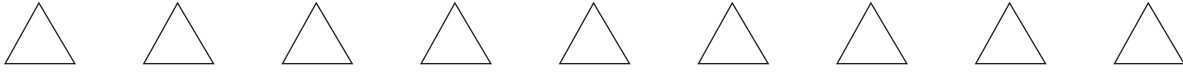

44. For the real number  $x$ , which of the following statements is true about the solutions of the equations below?

I.  $\frac{|x|}{5} = \frac{12\frac{3}{8}}{56.79}$

II.  $\frac{x}{5} = \frac{12\frac{3}{8}}{-56.79}$

- F. One of the 2 solutions of I is also a solution of II.  
 G. One of the 2 solutions of II is also a solution of I.  
 H. I and II have exactly the same solutions.  
 J. I and II both have infinitely many solutions.  
 K. II has exactly 1 more solution than I.
45. The solid rectangular prism shown below was built by alternating congruent black cubes and white cubes such that 2 cubes of the same color have at most 1 edge touching. What is the total number of *white* cubes that were used to build the prism?

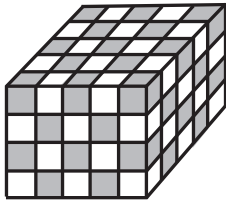

- A. 26  
 B. 48  
 C. 50  
 D. 54  
 E. 100
46. In the standard  $(x,y)$  coordinate plane, only 1 parabola of the form  $y = (x - h)^2 + k$  has  $x$ -intercepts of 3 and 15. Which of the following equations represents the axis of symmetry of this parabola?
- F.  $x = 3$   
 G.  $x = 9$   
 H.  $y = 9$   
 J.  $y = 3x + 15$   
 K.  $3x + 15y = 0$
47. What is the 330th digit after the decimal point in the repeating decimal  $4.\overline{6238}$  ?
- A. 2  
 B. 3  
 C. 4  
 D. 6  
 E. 8

**DO YOUR FIGURING HERE.**



48.  $\frac{a}{a+b} + \frac{b}{a-b} + \frac{a-b}{a+b} = ?$

F.  $\frac{2(a-b)}{a+b}$

G.  $\frac{2(a^2+b^2)}{a^2-b^2}$

H.  $\frac{2(a^2-ab+b^2)}{a^2-b^2}$

J.  $\frac{2a}{(a+b)(a-b)}$

K.  $\frac{2a}{3a+b}$

DO YOUR FIGURING HERE.

49. Counting repetition, how many prime factors appear in any prime factorization of the integer  $(63)^5$  ?

(Note: For example, counting repetition, 5 prime factors appear in the prime factorization of 588 as  $2 \cdot 2 \cdot 3 \cdot 7 \cdot 7$ .)

- A. 10  
 B. 15  
 C. 32  
 D. 243  
 E. 315

50. For whole numbers  $x$  and  $y$ , the list below has 4 as its mean, median, and mode. What is the value of  $xy$  ?

2, 6, 4, 1,  $x$ ,  $y$

- F. 16  
 G. 20  
 H. 24  
 J. 28  
 K. 32

51. Consider the graphs of the functions  $f(x) = (x+2)(x-8)$  and  $g(x) = x^2 + 5x - 12$  in the standard  $(x,y)$  coordinate plane. What is the sum of the  $y$ -intercepts of the functions?

- A. -28  
 B. -20  
 C. -18  
 D. -14  
 E. -12



52. The tablecloth shown below is white except for a pattern formed by 4 red rectangular strips, each 2 inches wide and 36 inches long, arranged as shown. If all of the angles formed by the strips are right angles, how many square inches of the tablecloth are red?

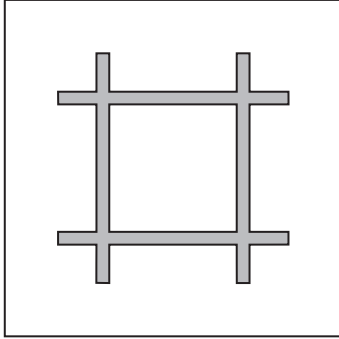

- F. 272  
 G. 284  
 H. 288  
 J. 304  
 K. Cannot be determined from the given information
53. For all real numbers  $x$  and  $y$ , the 2 operations  $\star$  and  $\diamond$  are defined below.

$$\begin{aligned}x \star y &= xy + y \\x \diamond y &= x + xy\end{aligned}$$

For all real numbers  $a$  and  $b$ , what is  $(a \diamond b) \star b$ ?

- A.  $a + ab^2 + b$   
 B.  $a + 2ab + b^2$   
 C.  $ab + ab^2$   
 D.  $ab + ab^2 + b$   
 E.  $ab + ab^2 + b + b^2$
54. If  $(x^y)(x^k) = 1$ , what relationship must exist between  $y$  and  $k$ ?
- F.  $y + k = 0$   
 G.  $y + k = 1$   
 H.  $yk = 0$   
 J.  $yk = 1$   
 K.  $y = k$

55. Which of the following numbers is a solution to the equation  $3x^2 + x + 5 = 0$ ?

- A.  $\frac{\sqrt{15}}{3}$   
 B.  $\frac{i\sqrt{15}}{3}$   
 C.  $\frac{-1 + \sqrt{61}}{6}$   
 D.  $\frac{-1 + i\sqrt{59}}{6}$   
 E.  $\frac{-1 + 2i\sqrt{15}}{6}$

DO YOUR FIGURING HERE.



56. In the standard  $(x,y)$  coordinate plane, one of the following is an equation of the circle that can be inscribed in the ellipse  $4x^2 + 9y^2 = 36$ . Which equation is that?

- F.  $x^2 + y^2 = 36$
- G.  $x^2 + y^2 = 9$
- H.  $x^2 + y^2 = 4$
- J.  $(x - 4)^2 + (y - 9)^2 = 36$
- K.  $(x - 9)^2 + (y - 4)^2 = 36$

DO YOUR FIGURING HERE.

57. In the figure below, points  $A$ ,  $B$ , and  $D$  lie on the circle with center  $C$ . The measure of  $\angle BCD$  is  $60^\circ$ . Chords  $\overline{AB}$  and  $\overline{AD}$  have the same length. What is the measure of  $\angle ABC$ ?

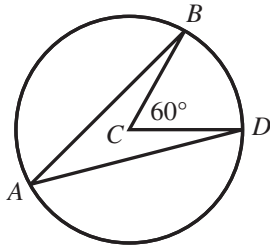

- A.  $10^\circ$
  - B.  $15^\circ$
  - C.  $20^\circ$
  - D.  $30^\circ$
  - E.  $40^\circ$
58. The 3 statements given below are all true about certain positive integers  $a$ ,  $b$ , and  $c$ .
- $a$  is an even prime number
  - $b$  is an odd integer such that  $6 < b < 11$
  - $c$  is a perfect square such that  $10 < c < 30$
- How many ordered triples  $(a,b,c)$  satisfy the 3 statements?
- F. 4
  - G. 5
  - H. 6
  - J. 8
  - K. Infinitely many

GO ON TO THE NEXT PAGE.



59. The side lengths of  $\triangle ABC$  shown below are 10 m, 18 m, and 21 m. Which of the following expressions represents the measure of  $\angle B$ ?

(Note: For a triangle with sides of length  $a$ ,  $b$ , and  $c$  that are opposite angles  $\angle A$ ,  $\angle B$ , and  $\angle C$ , respectively,  $c^2 = a^2 + b^2 - 2ab \cos \angle C$ .)

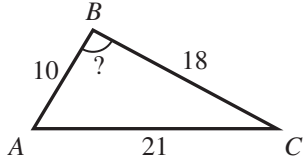

- A.  $\cos^{-1}(21^2 - 10^2 - 18^2 - 2(10)(18))$   
 B.  $\cos^{-1}(21^2 - 10^2 - 18^2 + 2(10)(18))$   
 C.  $\cos^{-1}(21^2 - 10^2 + 18^2 - 2(10)(18))$   
 D.  $\cos^{-1}\left(\frac{21^2 - 10^2 - 18^2}{-2(10)(18)}\right)$   
 E.  $\cos^{-1}\left(\frac{21^2 - 10^2 + 18^2}{-2(10)(18)}\right)$
60. The graph of  $f(x)$  is shown in the standard  $(x,y)$  coordinate plane below. The graph of  $f(x)$  has horizontal asymptotes at  $y = -2$  and  $y = 2$ . One of the following intervals represents the domain of  $f^{-1}(x)$ . Which one?

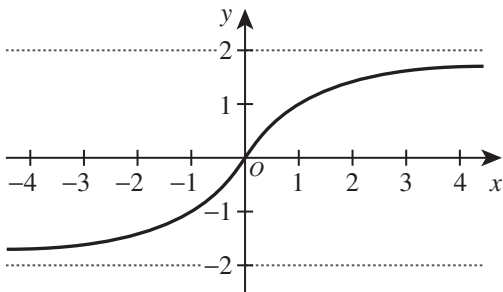

- F.  $(-2, 2)$   
 G.  $[-2, 2]$   
 H.  $(0, \infty)$   
 J.  $[0, \infty)$   
 K.  $(-\infty, \infty)$

**DO YOUR FIGURING HERE.**

**END OF TEST 2**

**STOP! DO NOT TURN THE PAGE UNTIL TOLD TO DO SO.**

**DO NOT RETURN TO THE PREVIOUS TEST.**



## READING TEST

35 Minutes—40 Questions

**DIRECTIONS:** There are several passages in this test. Each passage is accompanied by several questions. After reading a passage, choose the best answer to each question and fill in the corresponding oval on your answer document. You may refer to the passages as often as necessary.

## Passage I

**LITERARY NARRATIVE:** Passage A is adapted from the article “Ghost Bird” by Molly Loomis (©2011 by the Sierra Club). Passage B is adapted from the book *A Year on the Wing: Four Seasons in a Life with Birds* by Tim Dee (©2009 by Tim Dee).

## Passage A by Molly Loomis

“It’s a bird!” Tim shouts through the fog.

I drop my shovel into the cache I am digging and look up, frantically scanning the sky—afraid that, like a shooting star, the bird might vanish before I see it.

5 This is Antarctica. Deep Antarctica—a windswept glacier in the icy interior called the Branscomb. Here, no penguins waddle through rookeries, no seals slip between waves, no albatross glide over icebergs. It has been 43 days since I last saw a living creature other  
10 than a human.

The white body of a snow petrel blends into the dense fog—the outline of its outstretched wings, over-size sails for its delicate body, is barely visible. The bird hovers like a ghost, bobbing on a wave of wind. Its  
15 beady coal eyes and obsidian feet are the only signs of color. It circles, etching a carving into my memory.

With the subtle shift of a wing, the snow petrel charts a new course—evaporating into the milky soup that surrounds us. It is gone.

20 That night, with my hat pulled hard over my eyes to block out the ever-present daylight, I listen to the *rat-tat-tat* drumbeat of soft hail against my tent. The image of the petrel keeps resurfacing. Our encounter was brief—less than two minutes—but the lone bird  
25 swoops back and forth across the canvas of my closed eyes.

Despite their delicate physique and thin veil of feathers, snow petrels live in Antarctica year-round. They spend much of the year at sea, then at breeding  
30 time fly up to 200 miles inland to reunite with their mates and scratch out nests high on rocky outcroppings. Back and forth the birds fly from the land to the ocean, where they snatch krill, mollusks, and fish from the icy waters. The food sustains them and their chick until the  
35 fledgling is ready to fly.

I burrow deeper and listen to the wind grow to a whine. I think of the six plane rides it took to get here—Jackson to Salt Lake to Dallas to Santiago to Punta Arenas to Patriot Hills to Vinson. In a few weeks,  
40 we’ll retrace our journey back to warmer climes. And when we get home, we’ll share photos and stories and brag about our ability to survive in this stark, inhospitable place.

But the petrel, it will stay.

## Passage B by Tim Dee

45 Another day in September, I was crossing the Bay of Biscay on a ferry and had seen storm petrels. We were straining our eyes looking for spouting whales miles out across the silvery water toward the horizon. The wind was chasing us hard south and attending to  
50 the sea’s surface with diligence. It picked at acres of water, and as it rose in strength it seemed to go back over the sea to work on smaller and smaller patches until every square inch had its drama. And through this, barely over this, come flying migrant land birds.

55 Two miles of water were below me, a distance that is less known and less knowable than its equivalent in any other direction. By comparison, the thin air of birds’ lives seems solid and well mapped. Up from the sea’s depths, as from a dream, came fin whales; we slid  
60 past one another, and their jaws and undersides lit the sea with an otherworldly blue. Though the ferry was bigger, the vastness of the whale was stupendous. Its back broke the surface and it blew, and the sun caught its breath. Through these fleeting rainbow clouds tiny  
65 things appeared in my binoculars and grew to gannets as the ship reached them or they passed it. Then there was a tiny thing that didn’t grow and suddenly was upon us, whizzing overhead, and somehow drawn down toward the ferry and to me. I put down my binoculars  
70 and turned my head and two inches away from my face, perched on my left shoulder, was a willow warbler.

To see a land bird at sea is one way to feel how the earth is made and how it can fit a whale and a warbler together. The warbler weighs less than an ounce and  
75 has come from who-knows-where to the north; perhaps it was the bird that sang along the railway cutting at the back of my house this spring and lifted my journeys to work; perhaps it was a Norwegian bird, the descendant

of the three or four in a gully that I had helped flush  
 80 into a funnel trap on Fair Isle nearly thirty years before;  
 perhaps it was just a few weeks old and had never seen  
 the sea nor a man apparently standing on it. Its washed  
 green back was the same color as my coat; for a  
 moment we were a bleached and shrunken version of  
 85 Long John Silver and his parrot, sheltering in the lee of  
 the ferry's funnel. A second later either the bird realiz-  
 ed where it had landed or the wind whipped it from  
 my shoulder, and it let itself be lifted into the air, out to  
 the side of the boat, south over the whales and over the  
 90 sea.

Questions 1 and 2 ask about Passage A.

- The main point of the last two paragraphs of Passage A (lines 36–44) is that the narrator:
  - believes the trip back home will be easier to endure than her trip to get to Antarctica.
  - is disappointed in herself for deciding to leave the difficult Antarctic conditions and return home.
  - will boast about her own experience but believes the petrel better demonstrates survival skills.
  - traveled to Antarctica specifically to observe the petrel's behavior and survival skills.
- According to Passage A, snow petrels typically spend much of the year:
  - at sea, except during breeding season, when they fly back and forth between land and sea.
  - 200 miles inland, except when they must return to the ocean to catch food for their young.
  - migrating north in colder seasons and returning to Antarctica when temperatures rise.
  - flying back and forth from land to ocean in search of a mate.

Questions 3–7 ask about Passage B.

- The main purpose of the first paragraph of Passage B (lines 45–54) is to:
  - provide background information about whales in the Bay of Biscay.
  - indicate the narrator's fear that the day is too windy for any whale sightings.
  - establish a setting for the narrator's experience while whale watching.
  - show a contrast between whale behavior and migrant bird behavior.

- According to Passage B, when did the narrator recognize that the "tiny thing" he saw was a willow warbler?
  - When the bird flew over the narrator's head
  - When the bird was lifted into the air and began to fly away
  - When the narrator noticed the similarities between this bird and one he had seen near his house
  - When the narrator turned his head to see the bird on his shoulder
- As it is used in line 77, the word *lifted* most nearly means:
  - moved up.
  - removed.
  - climbed.
  - cheered.
- When the narrator of Passage B says "every square inch had its drama" (line 53), he most nearly means that:
  - the moving water reminded him of a piece of art.
  - none of the water within sight was smooth or calm.
  - the water seemed to indicate that he was about to have a dramatic encounter.
  - he felt his emotions rise as the ferry sailed through the bay.
- According to Passage B, the rainbow clouds the narrator observes through his binoculars are caused by:
  - sunlight shining through the whale's exhalation.
  - water droplets on the binocular lenses.
  - birds flying straight into the binoculars' line of sight.
  - reflections of blue from the whales' bodies.

Questions 8–10 ask about both passages.

- One element of the description of the bird encounter that is prominent in Passage A but absent in Passage B is:
  - the narrator's direct physical contact with the bird.
  - the narrator's contemplation of the difference between the narrator's life and the bird's life.
  - an indication that the bird is aware of the narrator's presence.
  - an indication of the direction the bird flies just before moving out of sight.
- The perspectives from which the passages are told can best be described as being:
  - similar; both passages describe events as they happen but include occasional flashbacks.
  - similar; both passages only describe events that occurred in the past.
  - different; Passage A mostly describes events as they happen, whereas Passage B mostly describes events that occurred in the past.
  - different; Passage A mostly describes events that occurred in the past, whereas Passage B mostly describes events as they happen.

10. Which quotation from Passage B most clearly resembles the moment in Passage A when “the snow petrel charts a new course—evaporating into the milky soup that surrounds us” (lines 17–19)?
- F. “The wind was chasing us hard south and attending to the sea’s surface with diligence” (lines 49–50).
- G. “Their jaws and undersides lit the sea with an otherworldly blue” (lines 60–61).
- H. “Perhaps it was just a few weeks old and had never seen the sea” (lines 81–82).
- J. “It let itself be lifted into the air, out to the side of the boat, south over the whales and over the sea” (lines 88–90).

### Passage II

**SOCIAL SCIENCE:** This passage is adapted from the article “The Gift of Doubt” by Malcolm Gladwell (©2013 by Condé Nast).

In the mid-nineteenth century, work began on a crucial section of the railway line connecting Boston to the Hudson River. The addition would run from Greenfield, Massachusetts, to Troy, New York, and it required  
5 tunneling through Hoosac Mountain, a massive impediment, nearly five miles thick, that blocked passage between the Deerfield Valley and a tributary of the Hudson.

James Hayward, one of New England’s leading  
10 railroad engineers, estimated that penetrating the Hoosac would cost, at most, a very manageable two million dollars. The president of Amherst College, an accomplished geologist, said that the mountain was composed of soft rock and that tunneling would be  
15 fairly easy once the engineers had breached the surface. “The Hoosac . . . is believed to be the only barrier between Boston and the Pacific,” the project’s promoter, Alvah Crocker, declared.

Everyone was wrong. Digging through the Hoosac  
20 turned out to be a nightmare. The project cost more than ten times the budgeted estimate. If the people involved had known the true nature of the challenges they faced, they would never have funded the Troy-Greenfield railroad. But, had they not, the factories of  
25 northwestern Massachusetts wouldn’t have been able to ship their goods so easily to the expanding West, the cost of freight would have remained stubbornly high, and the state of Massachusetts would have been immeasurably poorer. So is ignorance an impediment to  
30 progress or a precondition for it?

The economist Albert O. Hirschman loved paradoxes like this. He was a “planner,” the kind of economist who conceives of grand infrastructure projects and bold schemes. But his eye was drawn to the many ways  
35 in which plans did not turn out the way they were supposed to—to unintended consequences and perverse outcomes and the puzzling fact that the shortest line between two points is often a dead end.

“The Principle of the Hiding Hand,” one of  
40 Hirschman’s many memorable essays, drew on an account of the Troy-Greenfield “folly,” and then presented an even more elaborate series of paradoxes. Hirschman had studied the enormous Karnaphuli Paper Mills, in what was then East Pakistan. The mill was  
45 built to exploit the vast bamboo forests of the Chittagong Hill Tracts. But not long after the mill came online the bamboo unexpectedly flowered and then died, a phenomenon now known to recur every fifty years or so. Dead bamboo was useless for pulping; it  
50 fell apart as it was floated down the river. Because of ignorance and bad planning, a new, multimillion-dollar industrial plant was suddenly without the raw material it needed to function.

But what impressed Hirschman was the response  
55 to the crisis. The mill’s operators quickly found ways to bring in bamboo from villages throughout East Pakistan, building a new supply chain using the country’s many waterways. They started a research program to find faster-growing species of bamboo to replace the  
60 dead forests, and planted an experimental tract. They found other kinds of lumber that worked just as well. The result was that the plant was blessed with a far more diversified base of raw materials than had ever been imagined. If bad planning hadn’t led to the crisis  
65 at the Karnaphuli plant, the mill’s operators would never have been forced to be creative. And the plant would not have been nearly as valuable as it became.

“We may be dealing here with a general principle of action,” Hirschman wrote:

70 Creativity always comes as a surprise to us; therefore we can never count on it and we dare not believe in it until it has happened. In other words, we would not consciously engage upon  
75 tasks whose success clearly requires that creativity be forthcoming. Hence, the only way in which we can bring our creative resources fully into play is by misjudging the nature of the task, by presenting it to ourselves as more routine, simple, undemanding of genuine creativity  
80 than it will turn out to be.

And from there Hirschman’s analysis took flight. People don’t seek out challenges, he went on. They are “apt to take on and plunge into new tasks because of the erroneously presumed *absence* of a challenge—because  
85 the task looks easier and more manageable than it will turn out to be.” This was the Hiding Hand principle. The entrepreneur takes risks but does not see himself as a risk-taker, because he operates under the useful delusion that what he’s attempting is not risky. Then,  
90 trapped in mid-mountain, people discover the truth—and, because it is too late to turn back, they’re forced to finish the job.

11. The main point of the passage is that:
- A. large public projects often end up costing much more than the planners anticipate.
  - B. people who accomplish difficult feats often begin by underestimating the challenges they will face.
  - C. Hirschman believed that effective planners are more likely to do well at creative tasks.
  - D. people need a variety of resources to accomplish daily tasks.
12. In contrast to the Hoosac tunnel anecdote, the Karnaphuli mill anecdote includes information about the:
- F. specific ways that the problem was solved.
  - G. reasons that people invested in the project.
  - H. positive outcomes of the project.
  - J. unexpected problem that arose.
13. Based on the passage, the best example of a “useful delusion” (lines 88–89) is:
- A. Hirschman’s conviction that economic paradoxes exist.
  - B. Hayward’s belief that the Hoosac tunnel would cost two million dollars.
  - C. the passage author’s view that the Hoosac tunnel helped Massachusetts.
  - D. the mill operators’ idea to cultivate experimental bamboo tracts.
14. Based on the passage, the passage author would most likely agree that Hirschman was a man who:
- F. wasn’t an effective planner.
  - G. was interesting but didn’t always make sense.
  - H. maliciously enjoyed other people’s failure.
  - J. wrote memorably and had intriguing ideas.
15. The main idea of the second paragraph (lines 9–18) is that consultants on the Hoosac tunnel project:
- A. understood that Hoosac Mountain was the only barrier between Boston and the Pacific.
  - B. included a leading engineer, the president of Amherst College, and a promoter.
  - C. were confident that the project was manageable and worthwhile.
  - D. were not qualified to give opinions on the project.
16. In the context of the passage, the phrase “trapped in mid-mountain” (line 90) functions as both:
- F. a metaphor for situations that spark creativity and an allusion to the Hoosac tunnel anecdote.
  - G. a metaphor for situations that spark creativity and a personification of Hoosac Mountain.
  - H. foreshadowing of the Hiding Hand principle and an allusion to the Hoosac tunnel anecdote.
  - J. foreshadowing of the Hiding Hand principle and a personification of Hoosac Mountain.
17. Based on the passage, Hirschman’s interests were somewhat ironic in that he:
- A. encouraged others to seek challenges but didn’t seek them himself.
  - B. was a “planner” but saw benefit in projects not going according to plan.
  - C. wrote about creativity but wasn’t often creative in his work.
  - D. didn’t see himself as a risk taker but took risks as an entrepreneur.
18. Which of the following statements best summarizes the point Hirschman is making in lines 70–80?
- F. Our creativity fully emerges only during a task that is more difficult than we expected it to be.
  - G. We often misjudge our creative abilities, so we are usually surprised by our own creativity.
  - H. Using creativity can make the tasks we engage in less routine and simple.
  - J. Consciously making full use of our creative resources is the best way to begin a difficult task.
19. As it is used in line 40, the phrase *drew on* most nearly means:
- A. attracted.
  - B. dragged.
  - C. marked on.
  - D. referenced.
20. According to the passage, one reason dead bamboo is useless for pulping is that it:
- F. is less pliable.
  - G. won’t flower.
  - H. makes low-quality paper.
  - J. falls apart in water.

## Passage III

**HUMANITIES:** This passage is adapted from the article “Monk’s Art” by Fred Kaplan (©2008 by Washington Post.Newsweek Interactive Co. LLC).

Two of the most exciting jazz concerts I’ve seen in a long time were the recent Thelonious Monk tributes at Town Hall in New York, and one reason for the thrill—beyond the treat of hearing great music being played live by great musicians—was the sheer surprise that they *were* great, for tribute concerts tend to be, almost by nature, lame.

Certainly, there’s a place for jazz repertory—recitals of the classics—but, with some of those classics, the projects are fraught with doom from the get-go. For instance, Charlie Parker not only invented a new way of playing jazz; he also perfected it. A generation of alto saxophonists latched on to his style, but the best of them knew better than to play his tunes very often, for fear of inviting comparison, inevitably to their detriment.

Musicians who dare devote an entire album or concert to Thelonious Monk are toying with still more dangerous fire. Monk was a completely distinctive pianist. His jabbing dynamics, his jarring cadences, his oddball intervals that seem at once slapdash and preternaturally precise—he was to the keyboard what Picasso was to the canvas, and nobody can play or paint the same way, to the point where it’s a bit crazy to try. Most of those who make the attempt either round off the edges or sharpen them to the point of parody.

The Monk tributes at Town Hall faced a further challenge. Both were commemorating the 50th anniversary of a single concert—Monk’s first stab at leading a big band through his music, performed at the same Town Hall in February 1959. The concert was recorded live and released as an album that came to be hailed as a modern masterpiece. How do you duplicate—or otherwise capture “the spirit”—of that? Try to sound too much like Monk and you risk coming off as a pale imitation; try for something too different and you risk being dismissed as insufficiently Monkish.

The first of the two tribute concerts took the former course to an extreme degree. Charles Tolliver, an accomplished trumpeter and arranger who attended the 1959 concert as a teenager, was commissioned to transcribe all the parts (listening over and over to the album, since the original sheet music was lost long ago), put together a 10-piece band, and lead them through a straight re-creation of the event. The musicians were allowed to improvise their solos—this is jazz, after all—but the pianist, Stanley Cowell, was instructed to match Monk’s solos as closely as possible.

Miraculously, Tolliver pulled it off. The concert, which could have been an “academic” exercise, was anything but. The musicians had no doubt listened to the album countless times, but they owned these arrangements, playing them as if for the first time—not

too perfectly, not at all stiffly, leaving some space to sway in—and blowing solos that, in some cases, rivaled the originals.

The next night’s tribute concert—by Jason Moran and his Big Bandwagon, an octet extension of his Bandwagon trio—took the more adventurous path, seeking not to replicate the original but, rather, to use it as a leaping-off point.

Moran is attracted to conceptual art, meaning that he’s fascinated with process as part of the art. This fascination is what’s on display here—a sort of audio-video collage that explores the roots of Monk’s concert, of Monk himself, and of the ties that bind his music to Moran’s own path to jazz.

In most hands, this would be a formula for tweek disaster. But Moran, at 34 (meaning he was born 16 years after Monk’s 1959 concert), is one of the most versatile and imaginative jazz pianists of our time. Moran can play everything and play it brilliantly, preserving the integrity of the source while making it his own. And he does it again in this unlikely postmodern adventure with Monk.

Toward the end of the evening, Moran played Monk’s sweet ballad to his wife, “Crepuscle With Nellie.” Moran alternated the opening bars with a reverie of his own composition. When the rest of the band came in, the two themes weaved in and out of each other; Moran launched into an improvisation; the horn players devised their own variations on top of that. Meanwhile, a screen displayed some of W. Eugene Smith’s photos of Monk in his loft, mixed in with video footage taken recently inside the loft, which is now empty, the camera roaming across the bare wood boards. The sights and sounds swirled together like a kaleidoscope; it had the effect of a dream, a furtive glimpse of a life voyage.

And did I mention that it cooked like crazy?

21. The main purpose of the passage is to:

- A. describe the pitfalls of attempting to imitate great jazz musicians in concert.
- B. review the qualities of two jazz tribute concerts.
- C. trace the rise in popularity of jazz tribute concerts.
- D. persuade readers to attend two upcoming jazz concerts.

22. According to the passage, how did Tolliver's concert compare with Monk's concert?
- F. Although Tolliver's concert closely imitated Monk's style, Tolliver's concert featured a very different collection of songs.
  - G. Even though Tolliver featured instruments that were not used in Monk's concert, Tolliver's musicians closely imitated Monk's sound.
  - H. Most of Tolliver's musicians sounded as if they were playing the music for the first time, whereas Monk's musicians sounded well versed.
  - J. Although most of Tolliver's musicians improvised their solos, the majority of Tolliver's concert replicated Monk's concert.
23. As it is used in line 8, the phrase "there's a place for jazz repertory" most nearly refers to:
- A. Town Hall in New York City.
  - B. New York City concert halls in general.
  - C. the idea that musicians should perform jazz classics.
  - D. the specific years in history when jazz was most popular.
24. In attempting to describe Monk's talent, the author uses an analogy that compares Monk's:
- F. 1959 concert with the best tribute concerts the author has attended.
  - G. unusual intervals and cadences with Moran's unique use of video.
  - H. versatility in the 1959 concert with Parker's inventiveness on saxophone.
  - J. originality on the keyboard with Picasso's creativity in painting.
25. The author states that the tribute concerts he attended commemorated the:
- A. concert in which Monk himself paid tribute to Parker's style of jazz.
  - B. first concert in which Monk led a big band through his music.
  - C. opening of Town Hall in New York City.
  - D. release of a film featuring photos of Monk in his loft.
26. It can reasonably be inferred from the passage that in the 1959 concert, Monk played:
- F. trumpet.
  - G. piano.
  - H. saxophone.
  - J. no instrument; he conducted the music.
27. In the context of the passage, the statement that Tolliver's musicians "owned these arrangements" (lines 52–53) most nearly means Tolliver's musicians:
- A. held the copyright to Monk's music because the original sheet music had been lost.
  - B. played so well that they sounded as if they had created the musical arrangements themselves.
  - C. wrongly claimed the arrangements were their own creation.
  - D. received copies of the sheet music transcribed by Tolliver.
28. According to the passage, which tribute concert did the author consider the more adventurous?
- F. Tolliver's, because Tolliver was able to showcase how Monk perfected a new style of jazz.
  - G. Tolliver's, because Tolliver dared to replicate Monk's music so completely.
  - H. Moran's, because Moran used eight musicians rather than ten.
  - J. Moran's, because Moran used Monk's music as a springboard to create something new.
29. The main purpose of the eighth paragraph (lines 62–67) is to:
- A. provide a setup for the description of Moran's tribute by explaining Moran's approach to art in general.
  - B. demonstrate the author's skepticism concerning Moran's postmodern jazz compositions.
  - C. illustrate the contrast between Monk's and Moran's styles of jazz.
  - D. argue that Moran's versatility in integrating video and music makes Moran a better musician than Tolliver.
30. The parenthetical comment in lines 69–70 most strongly emphasizes the author's:
- F. appreciation of Moran's accomplishment, given that Moran was so far removed from Monk's era.
  - G. belief that Moran and Monk would have been a great jazz duo if Moran had been born earlier than he was.
  - H. idea that Moran is too young to adequately capture the maturity of Monk's style.
  - J. interest in analyzing Monk's concert and Moran's tribute as key moments in the development of jazz.

## Passage IV

**NATURAL SCIENCE:** This passage is adapted from the book *What a Plant Knows: A Field Guide to the Senses* by Daniel Chamovitz (©2012 by Daniel Chamovitz).

Closing the trap of a Venus flytrap requires a huge expense of energy, and reopening the trap can take several hours, so the plant only wants to spring closed when it's sure that the dawdling insect visiting its surface is large enough to be worth its time. The large black hairs on their lobes allow the Venus flytraps to literally feel their prey, and they act as triggers that spring the trap closed when the proper prey makes its way across the trap. If the insect touches just one hair, the trap will not spring shut; but a large enough bug will likely touch two hairs within about twenty seconds, and that signal springs the Venus flytrap into action.

We can look at this system as analogous to short-term memory. First, the flytrap encodes the information (forms the memory) that something (it doesn't know what) has touched one of its hairs. Then it stores this information for a number of seconds (retains the memory) and finally retrieves this information (recalls the memory) once a second hair is touched. If a small ant takes a while to get from one hair to the next, the trap will have forgotten the first touch by the time the ant brushes up against the next hair. In other words, it loses the storage of the information, doesn't close, and the ant happily meanders on. How does the plant encode and store the information from the unassuming bug's encounter with the first hair? How does it remember the first touch in order to react upon the second?

Scientists have been puzzled by these questions ever since John Burdon-Sanderson's early report on the physiology of the Venus flytrap in 1882. A century later, Dieter Hodick and Andreas Sievers at the University of Bonn in Germany proposed that the flytrap stored information regarding how many hairs have been touched in the electric charge of its leaf. Their model is quite elegant in its simplicity. In their studies, they discovered that touching a trigger hair on the Venus flytrap causes an electric action potential that induces calcium channels to open in the trap (this coupling of action potentials and the opening of calcium channels is similar to the processes that occur during communication between human neurons), thus causing a rapid increase in the concentration of calcium ions.

They proposed that the trap requires a relatively high concentration of calcium in order to close and that a single action potential from just one trigger hair being touched does not reach this level. Therefore, a second hair needs to be stimulated to push the calcium concentration over this threshold and spring the trap. The encoding of the information is in the initial rise in calcium levels. The retention of the information requires maintaining a high enough level of calcium so that a second increase (triggered by touching the second hair) pushes the total concentration of calcium over the threshold. As the calcium ion concentrations dissipate over time, if the second touch and potential don't

happen quickly, the final concentration after the second trigger won't be high enough to close the trap, and the memory is lost.

Subsequent research supports this model. Alexander Volkov and his colleagues at Oakwood University in Alabama first demonstrated that it is indeed electricity that causes the Venus flytrap to close. To test the model they rigged up very fine electrodes and applied an electrical current to the open lobes of the trap. This made the trap close without any direct touch to its trigger hairs (while they didn't measure calcium levels, the current likely led to increases). When they modified this experiment by alternating the amount of electrical current, Volkov could determine the exact electrical charge needed for the trap to close. As long as fourteen microcoulombs—a tiny bit more than the static electricity generated by rubbing two balloons together—flowed between the two electrodes, the trap closed. This could come as one large burst or as a series of smaller charges within twenty seconds. If it took longer than twenty seconds to accumulate the total charge, the trap would remain open.

Here, then, lies the proposed mechanism of the short-term memory in the Venus flytrap. The first touch of a hair activates an electric potential that radiates from cell to cell. This electric charge is stored as an increase in ion concentrations for a short time until it dissipates within about twenty seconds. But if a second action potential reaches the midrib within this time, the cumulative charge and ion concentrations pass the threshold and the trap closes.

31. The main question the passage addresses is how the Venus flytrap is able to:
- A. remain open after one of its trigger hairs has been touched.
  - B. release calcium after one trigger hair on its trap has been touched.
  - C. store the information that one trigger hair has been touched so it can close if a second hair is touched.
  - D. determine how long it should wait before closing after an insect has touched two trigger hairs.
32. Based on the passage, under which of the following circumstances would the Venus flytrap remain open?
- F. A second trigger hair is touched fifteen seconds after the first trigger hair is touched.
  - G. A second trigger hair is touched twenty-five seconds after the first trigger hair is touched.
  - H. Fifteen microcoulombs of electricity are applied to the plant's lobes.
  - J. Twenty microcoulombs of electricity are applied to the plant's lobes.

33. Based on the passage, what is the relationship between Hodick and Sievers's model and Volkov's research?
- A. Volkov's research supported the model Hodick and Sievers had proposed earlier.
  - B. Volkov's research proved that Hodick and Sievers's model was inaccurate.
  - C. Volkov's research laid the foundation for the model Hodick and Sievers later developed.
  - D. Volkov's research was verified by Hodick and Sievers when they developed their model.
34. The passage makes clear that unlike Hodick and Sievers's research on the Venus flytrap, Volkov's research did not examine:
- F. whether the flytrap could close without having a trigger hair touched.
  - G. what specific insects the flytrap is most likely to capture.
  - H. how much electricity is needed to close the flytrap.
  - J. the role calcium levels play in closing the flytrap.
35. The main idea of lines 13–24 is that the Venus flytrap's process for catching prey:
- A. can be thwarted if an insect touches only one trigger hair.
  - B. is especially effective at trapping ants.
  - C. is similar to how short-term memory functions.
  - D. uses memory more effectively than other plants' processes do.
36. Based on the passage, Burdon-Sanderson is significant in the study of Venus flytraps primarily because he:
- F. discovered the Venus flytrap in 1882.
  - G. composed an early report on the Venus flytrap's physiology.
  - H. determined that Venus flytraps could store electric charges.
  - J. discovered what causes Venus flytraps to close.
37. In the passage, the idea that closing the Venus flytrap demands a large amount of energy is presented by the passage author as:
- A. an opinion held by Hodick and Sievers.
  - B. an opinion that has yet to be tested.
  - C. a theory supported by Volkov's research.
  - D. a fact.
38. Based on the passage, the example in lines 19–24 of the ant crawling on the Venus flytrap most nearly serves to show:
- F. how the flytrap stores the information that a second trigger hair was touched.
  - G. the process the flytrap uses to differentiate between insects and other animals.
  - H. a situation in which touching a second trigger hair doesn't make the flytrap close.
  - J. the amount of time it takes for the flytrap to close once a second trigger hair is touched.
39. As it is used in line 48, the word *spring* most nearly means:
- A. break.
  - B. vault.
  - C. activate.
  - D. grow.
40. Based on the passage, compared to the amount of static electricity generated by rubbing two balloons together, the amount of electricity needed to close the Venus flytrap is:
- F. slightly greater.
  - G. exactly the same.
  - H. slightly less.
  - J. significantly less.

**END OF TEST 3**

**STOP! DO NOT TURN THE PAGE UNTIL TOLD TO DO SO.**

**DO NOT RETURN TO A PREVIOUS TEST.**





## SCIENCE TEST

35 Minutes—40 Questions

**DIRECTIONS:** There are several passages in this test. Each passage is followed by several questions. After reading a passage, choose the best answer to each question and fill in the corresponding oval on your answer document. You may refer to the passages as often as necessary.

You are NOT permitted to use a calculator on this test.

## Passage I

*Caenorhabditis elegans* (roundworms about 1 mm long) are attracted to some chemical compounds. *C. elegans* can become desensitized to a compound, making them less likely to move toward that compound, if they are exposed to the compound over a period of time. Students conducted 2 experiments to study this process—called *chemosensory adaptation*—in *C. elegans*.

## Experiment 1

To determine if *C. elegans* are attracted to Compounds X, Y, and Z, the students prepared 3 petri dishes (Dishes 1–3). On Dish 1, a drop of Compound X was placed on 1 edge of the dish, and a drop of Compound Y was placed on the opposite edge of the dish. A drop of Drug P, which temporarily paralyzes *C. elegans* upon contact, was placed next to each compound, and 100 *C. elegans* were placed in the middle of the dish (see Figure 1). This procedure was repeated for Dish 2, except with Compounds X and Z, and for Dish 3, except with Compounds Y and Z. The dishes were incubated for 1 hr. Table 1 shows, for each dish, the percent of *C. elegans* that moved toward each compound present.

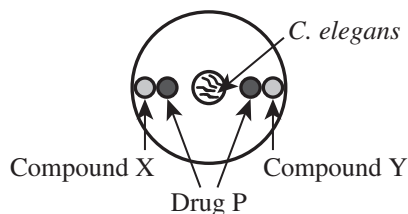

Figure 1

Dish	Percent of <i>C. elegans</i> that moved toward Compound:		
	X	Y	Z
1	82	18	—
2	59	—	41
3	—	33	67

Note: A dash indicates the compound was not present.

## Experiment 2

Six hundred *C. elegans* were divided into 3 equal groups. Each group was pre-exposed to Compound X for a different period of time: 0 min, 10 min, or 120 min. Then, each group was placed in the center of a separate dish that was identical to Dish 2 as prepared in Experiment 1. The dishes were incubated for 1 hr. Figure 2 shows the percent of *C. elegans* that moved toward each compound on each dish.

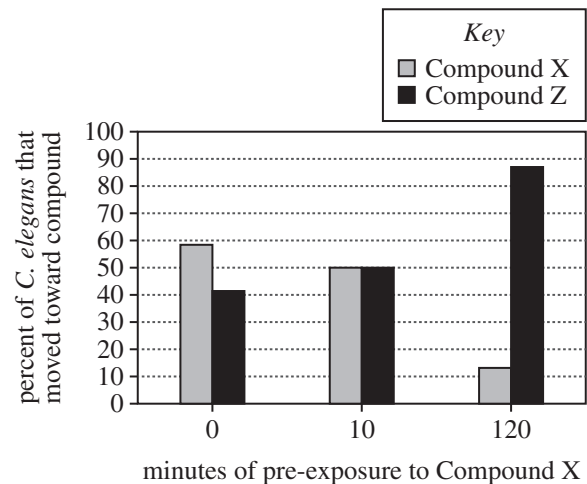

Figure 2

Table and figures adapted from Tim Lindblom, "A Chemosensory Adaptation Module for the Physiology Laboratory from Student-Directed *C. elegans* Research." ©2006 by National Association of Biology Teachers.

- To determine how many *C. elegans* moved toward each compound in Experiments 1 and 2, the students most likely used which of the following pieces of laboratory equipment?
  - Balance
  - Graduated cylinder
  - Microscope
  - pH meter



2. Based on the results of Experiment 1, the *C. elegans* were most attracted to which of Compounds X, Y, or Z, if any?
- F. Compound X  
G. Compound Y  
H. Compound Z  
J. None of the compounds; the *C. elegans* were equally attracted to each of the 3 compounds.

3. On Dish 3 in Experiment 1, the number of *C. elegans* that moved toward Compound Z was approximately how many times as great as the number of *C. elegans* that moved toward Compound Y?

- A.  $\frac{1}{4}$   
B.  $\frac{1}{2}$   
C. 2  
D. 4

4. The single-dish experimental design shown in which of the following figures would best allowed the students to determine which compound (X, Y, or Z) was most attractive to the *C. elegans*?

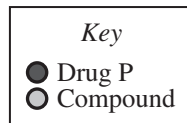

F.

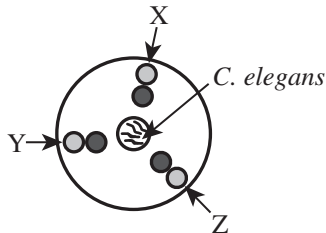

G.

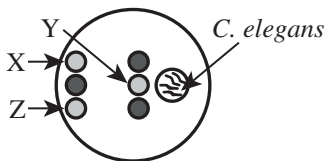

H.

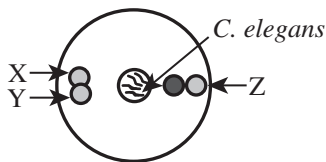

J.

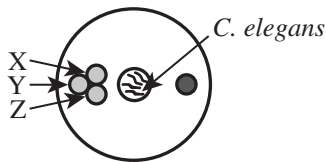

5. In Experiments 1 and 2 combined, Compound Z was placed on a total of how many dishes?

- A. 0  
B. 2  
C. 5  
D. 6

6. Based on the description of *C. elegans* in the passage, a cell from a *C. elegans* lacks which of the following structures?

- F. Cell wall  
G. Mitochondria  
H. Nucleus  
J. Plasma membrane

7. In Experiment 2, as the amount of pre-exposure time increased, did the number of *C. elegans* that were attracted to Compound Z increase or decrease?

- A. Increase, because the *C. elegans* experienced chemosensory adaptation to Compound X.  
B. Increase, because the *C. elegans* experienced chemosensory adaptation to Compound Z.  
C. Decrease, because the *C. elegans* experienced chemosensory adaptation to Compound X.  
D. Decrease, because the *C. elegans* experienced chemosensory adaptation to Compound Z.



## Passage II

In the python (*Python molurus*), a species of snake, organ mass and metabolic rate may decrease between meals, conserving energy. Figure 1 shows, for a group of juvenile pythons (Group V), the average mass of the small intestine before and after each python ingested a single meal that had a mass equal to 25% of the python's body mass. Figure 2 shows, for 4 groups of juvenile pythons (Groups W–Z), the average oxygen consumption rate, in milliliters of oxygen consumed per gram of body mass per hour (mL/g/hr), before and after each python ingested a single meal. Table 1 shows the relative mass of the meal ingested by the pythons in each group.

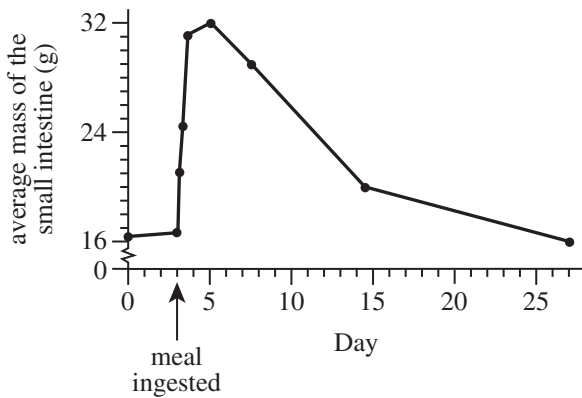

Figure 1

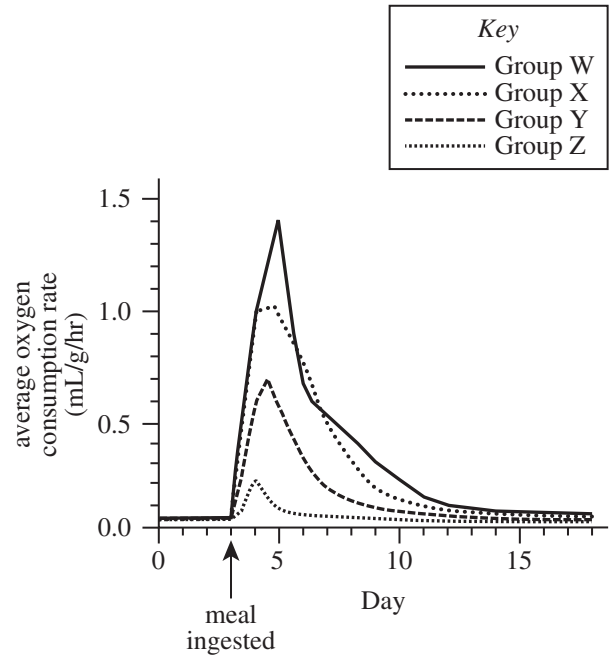

Figure 2

Table 1	
Group	Each python ingested a meal that had a mass equal to:
W	100% of the python's body mass
X	65% of the python's body mass
Y	35% of the python's body mass
Z	5% of the python's body mass

Table and figures adapted from Stephen M. Secor and Jared Diamond, "A Vertebrate Model of Extreme Physiological Regulation." ©1998 by Nature Publishing Group, a division of Macmillan Publishers Limited.



8. For Group V, on which of the following days was the average mass of the small intestine approximately twice as great as it was on Day 0 ?
- F. Day 2
  - G. Day 5
  - H. Day 12
  - J. Day 20
9. According to Figure 1, before the Group V pythons ingested a meal, the average mass of their small intestines was approximately:
- A. 16 g.
  - B. 20 g.
  - C. 24 g.
  - D. 32 g.
10. Based on Figures 1 and 2, when Group Y had an average oxygen consumption rate of 0.05 mL/g/hr between Day 0 and Day 5, the average mass of the small intestine for Group Y was most likely closest to which of the following values?
- (Note: Assume that the pythons in Group V and the pythons in Group Y had approximately the same mass on Day 0.)
- F. 1 g
  - G. 15 g
  - H. 65 g
  - J. 100 g
11. A juvenile python in one of the groups listed in Table 1 had a body mass of 1,000 g and ingested a meal that had a mass of 50 g. That python was most likely in Group:
- A. W.
  - B. X.
  - C. Y.
  - D. Z.
12. Based on Figure 2, the average metabolic rate for the Group W pythons was most likely greatest approximately how many days after they ingested their meal?
- F. 2
  - G. 5
  - H. 10
  - J. 18
13. Suppose the average oxygen consumption rate of the Group V pythons had been determined 1 day after they ingested their meal. Based on Table 1 and Figure 2, the oxygen consumption rate would most likely have been:
- A. less than 0.2 mL/g/hr.
  - B. between 0.2 mL/g/hr and 0.6 mL/g/hr.
  - C. between 0.6 mL/g/hr and 1.0 mL/g/hr.
  - D. greater than 1.0 mL/g/hr.

**Passage III**

The *solubility* of a substance is typically defined as the maximum mass, in grams (g), of the substance (the solute) that will stay dissolved in 100 g of a solvent (such as water). The solubility of a substance generally varies as the temperature of the solvent changes. Figure 1 shows, for each of 5 substances, how solubility in water varies with temperature.

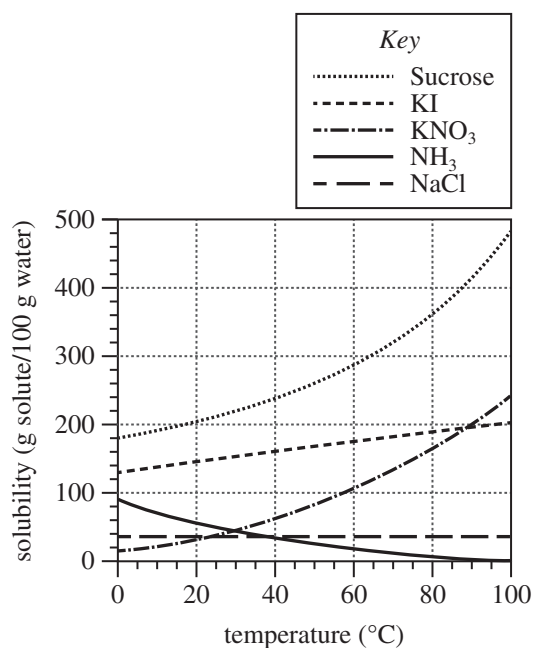

Figure 1

Figure 2 shows, for 3 temperatures (25°C, 40°C, and 60°C), how the solubility of sucrose varies as the percent by mass of water in solvent mixtures of water and ethanol varies.

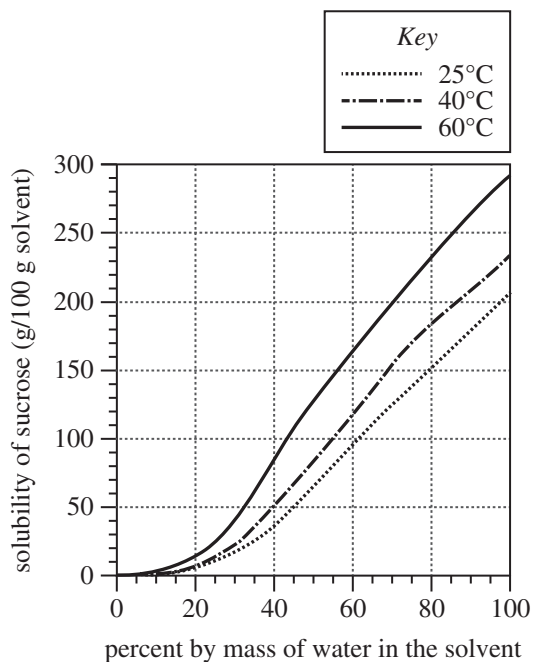

Figure 2

Figure 2 adapted from A. M. Peres and E. A. Macedo, "Phase Equilibria of D-glucose and Sucrose in Mixed Solvent Mixtures: Comparison of UNIQUAC-based Models." ©1997 by Elsevier Science Ltd.



14. According to Figure 1, the solubility of  $\text{KNO}_3$  in water at  $50^\circ\text{C}$  is closest to which of the following values?
- F. 30 g  $\text{KNO}_3/100$  g water  
 G. 85 g  $\text{KNO}_3/100$  g water  
 H. 170 g  $\text{KNO}_3/100$  g water  
 J. 250 g  $\text{KNO}_3/100$  g water
15. Based on Figure 1, approximately how many more grams of sucrose will stay dissolved in 100 g of water at  $80^\circ\text{C}$  than at  $20^\circ\text{C}$ ?
- A. 110 g  
 B. 160 g  
 C. 210 g  
 D. 370 g
16. Which of the following compounds shows the *least* variation in solubility as the temperature of water increases from  $0^\circ\text{C}$  to  $100^\circ\text{C}$ ?
- F. KI  
 G.  $\text{KNO}_3$   
 H. NaCl  
 J.  $\text{NH}_3$
17. Based on Figure 1, which of the substances represented in Figure 1 is most likely a gas?
- A.  $\text{NH}_3$  only, because the solubility of gases in water generally decreases as the temperature increases.  
 B.  $\text{NH}_3$  only, because the solubility of gases in water generally decreases as the temperature decreases.  
 C. Sucrose,  $\text{KNO}_3$ , KI, and NaCl only, because the solubility of gases in water generally decreases as the temperature increases.  
 D. Sucrose,  $\text{KNO}_3$ , KI, and NaCl only, because the solubility of gases in water generally decreases as the temperature decreases.
18. Based on Figure 2, does the solubility of sucrose generally increase as the percent ethanol in the solvent mixture increases, and does the solubility of sucrose generally increase as the temperature of the solvent increases?
- |    | <u>percent ethanol increases</u> | <u>temperature increases</u> |
|----|----------------------------------|------------------------------|
| F. | yes                              | yes                          |
| G. | yes                              | no                           |
| H. | no                               | yes                          |
| J. | no                               | no                           |
19. Based on Figure 1, the maximum mass of KI, in *milligrams* (NOT grams), that will stay dissolved in 100 g of water at  $20^\circ\text{C}$  is closest to which of the following?
- A. 140 mg KI/100 g water  
 B. 1,400 mg KI/100 g water  
 C. 14,000 mg KI/100 g water  
 D. 140,000 mg KI/100 g water



### Passage IV

Karymsky Lake is located within a volcanic *caldera* (a wide basin formed when the peak of a volcanic cone collapses). In April 1993, water samples were collected from the lake and analyzed for pH, for  $\text{Na}^+$ , and for  $\text{SO}_4^{2-}$ . On January 2, 1996, a 2-day-long underwater eruption occurred in the lake. The eruption produced a crater on the bottom of the lake at the north end (see diagram). In April 1996, water samples were again collected from the lake and analyzed for pH, for  $\text{Na}^+$ , and for  $\text{SO}_4^{2-}$ .

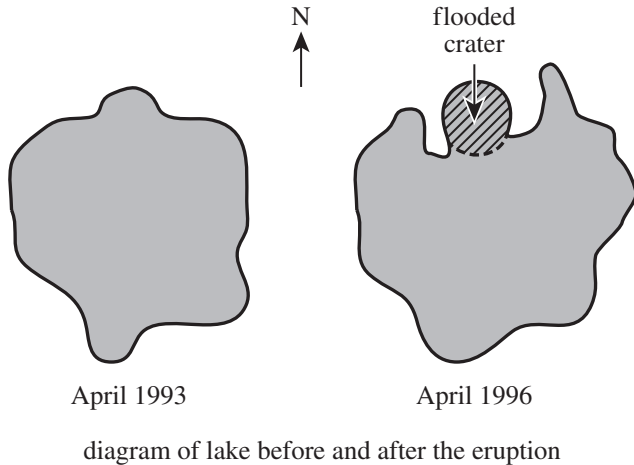

#### Study 1

On April 1, 1993, in the center of the lake, a set of water samples was collected at the surface (0 m depth) and at each of the following depths: 10 m, 20 m, 30 m, 40 m, 50 m, and 60 m. For each of the 3 analyses, the measurements were averaged for the set of water samples from each depth. The results for pH, and for  $\text{Na}^+$  and  $\text{SO}_4^{2-}$  contents, in milligrams per liter (mg/L), are shown in Figure 1.

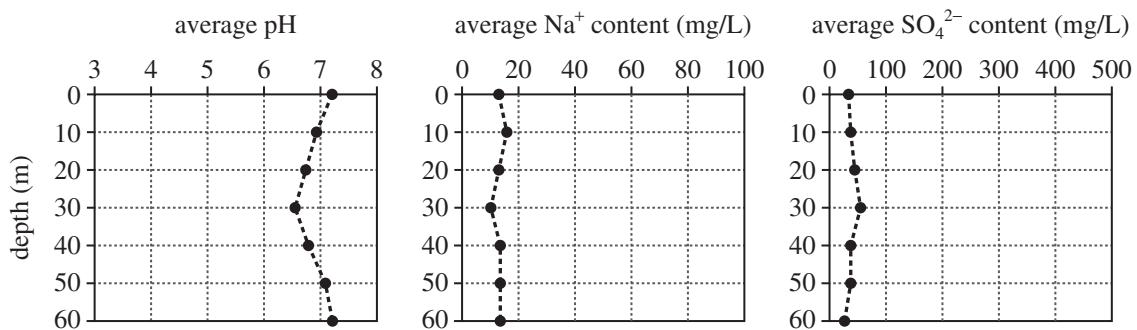

Figure 1

#### Study 2

On April 1, 1996, Study 1 was repeated, except at 2 locations in the lake—at the center of the lake where samples were collected in Study 1, and within the newly formed and flooded volcanic crater. The results are shown in Figure 2.

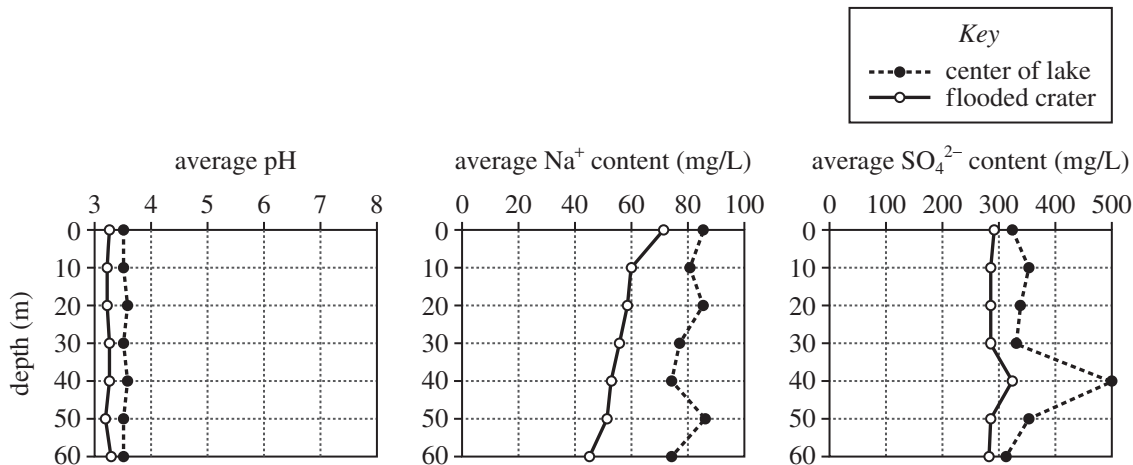

Figure 2

Figures adapted from S. M. Fazlullin et al., "The 1996 Subaqueous Eruption at Academii Nauk Volcano (Kamchatka) and Its Effects on Karymsky Lake." ©2000 by Elsevier B.V.

20. In Study 2, on average, at which location was the Na<sup>+</sup> content greater, and at which location was the SO<sub>4</sub><sup>2-</sup> content greater?

<u>Na<sup>+</sup> content</u>	<u>SO<sub>4</sub><sup>2-</sup> content</u>
-------------------------------	--

- |                          |                |
|--------------------------|----------------|
| <b>F.</b> center of lake | center of lake |
| <b>G.</b> center of lake | flooded crater |
| <b>H.</b> flooded crater | center of lake |
| <b>J.</b> flooded crater | flooded crater |
21. The 2 studies, taken together, would most likely have been useful in determining whether the eruption in January 1996 affected the:
- A.** temperature of the lake water.  
**B.** chemistry of the lake water.  
**C.** frequency of volcanic eruptions.  
**D.** severity of volcanic eruptions.
22. Approximately how many months after the eruption were water samples collected from the lake?
- F.** 1  
**G.** 2  
**H.** 3  
**J.** 4
23. Assume that the electrical conductivity of the lake water is determined only by the SO<sub>4</sub><sup>2-</sup> content. Also assume that the electrical conductivity and the SO<sub>4</sub><sup>2-</sup> content are directly related. Based on these assumptions and on the results of Study 2, on April 1, 1996, at what depth in the center of the lake, and at what depth in the flooded crater, would the electrical conductivity of the water most likely have been greatest?

	<u>center of lake</u>	<u>flooded crater</u>
--	-----------------------	-----------------------

- |           |      |      |
|-----------|------|------|
| <b>A.</b> | 40 m | 0 m  |
| <b>B.</b> | 40 m | 40 m |
| <b>C.</b> | 50 m | 0 m  |
| <b>D.</b> | 50 m | 50 m |

24. The types of fish that were present in the lake on April 1, 1993, could have survived even if the lake water pH had been 1.5 less than what it was on that date. What percent of the fish that were present in the lake on April 1, 1993, were most likely still present in the lake on April 1, 1996 ?

- F.** 0%  
**G.** 25%  
**H.** 75%  
**J.** 100%

25. On which date, April 1, 1993, or April 1, 1996, was the water collected in the center of the lake more acidic?

- A.** April 1, 1993, because the water collected on that date had the higher pH at every depth.  
**B.** April 1, 1993, because the water collected on that date had the lower pH at every depth.  
**C.** April 1, 1996, because the water collected on that date had the higher pH at every depth.  
**D.** April 1, 1996, because the water collected on that date had the lower pH at every depth.

26. In the studies, each set of water samples from a particular depth consisted of 5 individual samples. Given that information, how many individual water samples were collected on April 1, 1993 ?

- F.** 5  
**G.** 15  
**H.** 25  
**J.** 35



**Passage V**

The *law of definite proportions* states that the percent by mass of any given element in a chemical compound is always the same, regardless of how the compound is formed. The *law of conservation of mass* states that, in a chemical reaction, the total mass of products must equal the total mass of reactants.

To study these chemical laws, students performed an experiment in which zinc (Zn) and iodine (I<sub>2</sub>) reacted to form zinc iodide (ZnI<sub>2</sub>):

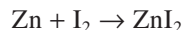
*Experiment*

In each of 5 trials, Steps 1–9 were performed:

1. A certain mass of Zn metal was placed into a flask.
2. A certain mass of I<sub>2</sub> was added to the flask.
3. Twenty-five mL of methanol (a solvent) was added to the flask, and the mouth of the flask was covered with aluminum foil.
4. The contents of the flask were boiled until a color change was observed (which signaled that the I<sub>2</sub> had been completely consumed).
5. The flask was allowed to cool, and the contents of the flask were filtered using filter paper.
6. The filter paper was dried, and the mass of unreacted Zn on the filter paper was determined.
7. The *filtrate* (the liquid that passed through the filter) was poured into a beaker and heated to evaporate the methanol, leaving a dry solid in the beaker.
8. The mass of the dry solid was measured.
9. The percent by mass of Zn and of I in the dry solid was calculated.

The results are shown in the table below.

Trial	Initial mass of Zn (g)	Initial mass of I <sub>2</sub> (g)	Mass of unreacted Zn (g)	Mass of dry solid (g)	Percent by mass of Zn in dry solid	Percent by mass of I in dry solid
1	2.00	2.00	1.49	2.52	20.2	79.8
2	2.00	3.00	1.23	3.77	20.4	79.6
3	2.00	4.00	0.96	5.04	20.6	79.4
4	3.00	2.00	2.48	2.51	20.7	79.3
5	4.00	2.00	3.51	2.53	19.4	80.6



27. Which of the following graphs best shows the mass of dry solid obtained in Trials 1–5 ?

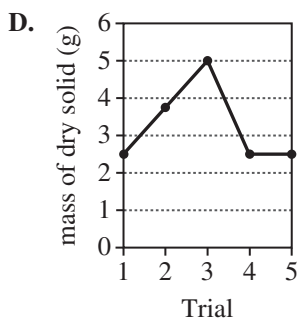
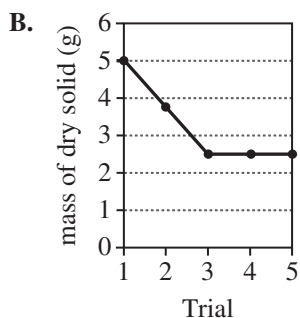
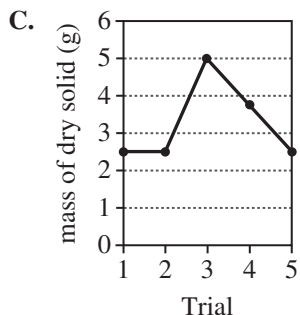
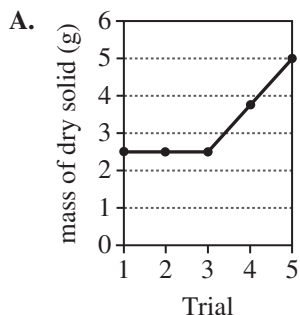

28. Consider the procedures in the experiment that are listed below.

1. Boil the contents of the flask.
2. Add a certain mass of  $I_2$  to the flask.
3. Filter the contents of the flask.
4. Add methanol to the flask.
5. Evaporate the methanol from the filtrate.

These procedures were performed in what order?

- F. 2, 4, 1, 3, 5  
 G. 2, 4, 3, 5, 1  
 H. 4, 2, 1, 3, 5  
 J. 4, 2, 3, 5, 1

29. Which of the following expressions gives the mass of Zn that reacted in Trial 1 ?

- A.  $2.00 \text{ g} + 1.49 \text{ g}$   
 B.  $2.00 \text{ g} - 1.49 \text{ g}$   
 C.  $2.00 \text{ g} \times 1.49 \text{ g}$   
 D.  $2.00 \text{ g} \div 1.49 \text{ g}$

30. Suppose a trial had been performed in the experiment with 2.00 g of Zn and 2.50 g of  $I_2$ . Based on the results of the experiment, the mass of unreacted Zn in this trial would most likely have been:

- F. less than 1.23 g.  
 G. between 1.23 g and 1.49 g.  
 H. between 1.49 g and 2.00 g.  
 J. greater than 2.00 g.

31. Which of the variables listed below were dependent variables in the experiment?

- I. Initial mass of  $I_2$
- II. Mass of unreacted Zn
- III. Mass of dry solid

- A. I and II only  
 B. I and III only  
 C. II and III only  
 D. I, II, and III

32. Consider the results of Trials 1–3. In those trials, as the initial mass of  $I_2$  increased, the mass of unreacted Zn:

- F. decreased only.  
 G. increased only.  
 H. decreased and then increased.  
 J. increased and then decreased.

33. Consider the trials in which the initial mass of  $I_2$  was 2.00 g. In those trials, as the initial mass of Zn increased, the mass of dry solid obtained:

- A. increased only.  
 B. decreased only.  
 C. increased and then decreased.  
 D. remained nearly constant.

**Passage VI**

Three students were asked to estimate the Sun's *life span* (the time that will have elapsed from the time the Sun began emitting energy until the time it exhausts its energy supply). The students were told that the Sun's mass is about  $10^{30}$  kg and that the Sun's rate of energy emission is about  $10^{34}$  joules per year (J/yr).

*Student 1*

Energy is produced in the Sun by the combustion of molecular hydrogen gas ( $H_2$ ). In this chemical reaction, 2 molecules of  $H_2$  react with 1 molecule of oxygen gas ( $O_2$ ). For every 1 kg of  $H_2$  molecules consumed, about  $10^8$  J of energy is produced. Therefore, if the Sun was composed entirely of  $H_2$  at the start of its life span, then the Sun will have exhausted its fuel in approximately:

$$10^{30} \text{ kg } H_2 \times \frac{10^8 \text{ J}}{1 \text{ kg } H_2} \times \frac{1 \text{ yr}}{10^{34} \text{ J}} = 10^4 \text{ yr}$$

Thus, the Sun's life span is 10 thousand years.

*Student 2*

Energy is not produced in the Sun. The Sun formed when an interstellar cloud collapsed under the force of its own gravity. The collapse converted the cloud's mechanical energy,  $E$ , into *thermal energy* (heat) that was stored in the forming solar core. The mechanical energy in the cloud is estimated to have been approximately  $10^{41}$  J. If 100% of this mechanical energy was converted to thermal energy as the Sun formed, then the Sun will have emitted all of it in approximately:

$$10^{41} \text{ J} \times \frac{1 \text{ yr}}{10^{34} \text{ J}} = 10^7 \text{ yr}$$

Thus, the Sun's life span is 10 million years.

*Student 3*

Energy is produced in the Sun by the fusion of hydrogen (H) nuclei. In this nuclear reaction, 4 H nuclei fuse together to form 1 helium (He) nucleus. For every 1 kg of H nuclei consumed, about  $10^{15}$  J of energy is produced. However, only within the *solar core* (the innermost 10% of the Sun's mass) are the temperature and pressure great enough for fusion to occur. Therefore, if the Sun was composed entirely of H at the start of its life span, then the Sun will have exhausted its fuel after approximately:

$$10^{29} \text{ kg } H \times \frac{10^{15} \text{ J}}{1 \text{ kg } H} \times \frac{1 \text{ yr}}{10^{34} \text{ J}} = 10^{10} \text{ yr}$$

Thus, the Sun's life span is 10 billion years.

34. Which of the students asserted that the Sun is emitting energy due to reactions involving some form of hydrogen?

- F. Students 1 and 2 only
- G. Students 1 and 3 only
- H. Students 2 and 3 only
- J. Students 1, 2, and 3

35. Suppose that Student 2 had done another estimate of the mechanical energy in the cloud and found that it was about  $10^{42}$  J. Student 2 would most likely revise the estimate of the Sun's life span to be:

- A. 1 million years.
- B. 5 million years.
- C. 100 million years.
- D. 500 million years.

36. Studies on the radioactive decay of materials in Earth rocks, Moon rocks, and samples obtained from asteroids and meteorites indicate that the solar system is at least  $4.5 \times 10^9$  yr old. These results *contradict* the estimate(s) for the Sun's life span given by which student(s)?

- F. Student 2 only
- G. Students 1 and 2 only
- H. Students 1 and 3 only
- J. Students 1, 2, and 3

37. Which of the following statements identifies a serious flaw in Student 1's discussion? Student 1 stated or implied that:

- A. combustion requires oxygen, but Student 1 did not include any oxygen in the Sun's composition.
- B. combustion is a chemical reaction, but combustion is a mechanical process.
- C. hydrogen exists as a diatomic molecule, but hydrogen exists only as individual atoms.
- D. oxygen exists as a diatomic molecule, but oxygen exists only as individual atoms.



38. Based on Student 3's discussion, to produce 16 He nuclei in the Sun's core, how many H nuclei must undergo fusion?
- F. 4
  - G. 16
  - H. 32
  - J. 64
39. Based on Student 1's description, the interaction of the 2 types of molecules involved in the Sun's energy production would yield which of the following substances?
- A. Carbon dioxide
  - B. Helium
  - C. Ozone
  - D. Water
40. Suppose that the Sun began producing energy approximately  $5 \times 10^9$  yr ago. Based on Student 3's estimate of the Sun's life span, approximately how many years of fuel does the Sun have left?
- F.  $1 \times 10^9$  yr
  - G.  $5 \times 10^9$  yr
  - H.  $1 \times 10^{10}$  yr
  - J.  $5 \times 10^{10}$  yr

**END OF TEST 4**

**STOP! DO NOT RETURN TO ANY OTHER TEST.**

## Scoring Keys for Form F11

Use the scoring key for each test to score your answer document for the multiple-choice tests. Mark a "1" in the blank for each question you answered correctly. Add up the numbers in each reporting category and enter the total number correct for each reporting category in the blanks provided. Also enter the total number correct for each test in the blanks provided. The total number correct for each test is the sum of the number correct in each reporting category.

### Test 1: English—Scoring Key

Key	Reporting Category*		
	POW	KLA	CSE
1. C			___
2. J			___
3. A			___
4. H	___		___
5. A	___		___
6. F	___		___
7. B	___		___
8. J			___
9. C			___
10. J		___	___
11. A			___
12. G	___		___
13. D		___	___
14. G		___	___
15. B	___		___
16. J		___	___
17. B			___
18. H	___		___
19. B			___
20. J			___
21. C			___
22. G	___		___
23. D			___
24. H			___
25. B	___		___
26. J	___		___
27. A			___
28. F	___		___
29. D			___
30. F	___		___
31. C	___		___
32. H		___	___
33. A			___
34. F			___
35. C			___
36. G			___
37. D	___		___
38. J			___

Key	Reporting Category*		
	POW	KLA	CSE
39. B			___
40. J			___
41. A	___		___
42. H	___		___
43. C		___	___
44. G	___		___
45. C		___	___
46. J			___
47. A			___
48. H			___
49. D		___	___
50. F			___
51. B			___
52. G	___		___
53. A	___		___
54. F			___
55. B			___
56. J		___	___
57. A	___		___
58. F			___
59. B		___	___
60. J	___		___
61. C			___
62. J		___	___
63. D	___		___
64. J	___		___
65. C			___
66. G			___
67. A			___
68. F			___
69. C			___
70. H			___
71. D			___
72. F			___
73. A		___	___
74. G	___		___
75. D	___		___

#### \*Reporting Categories

**POW** = Production of Writing

**KLA** = Knowledge of Language

**CSE** = Conventions of Standard English

Number Correct (Raw Score) for:	
Production of Writing (POW)	___ (23)
Knowledge of Language (KLA)	___ (12)
Conventions of Standard English (CSE)	___ (40)
Total Number Correct for English Test (POW + KLA + CSE)	___ (75)

**Test 2: Mathematics—Scoring Key**

Key	Reporting Category*						
	PHM					IES	MDL
	N	A	F	G	S		
1. E		—					
2. J		—					
3. D				—			
4. F			—				
5. D	—					—	—
6. K	—						
7. B					—		
8. F						—	
9. D					—		
10. H						—	
11. C						—	
12. F			—				
13. E			—				
14. F		—					
15. B		—				—	
16. J						—	—
17. E						—	—
18. F						—	
19. A					—		
20. H				—		—	
21. A		—					
22. F		—				—	—
23. D						—	
24. J					—		—
25. E						—	—
26. J						—	—
27. C						—	—
28. J						—	—
29. D			—			—	—
30. J						—	—

Key	Reporting Category*						
	PHM					IES	MDL
	N	A	F	G	S		
31. B						—	—
32. G	—						
33. E						—	
34. G						—	—
35. C						—	—
36. H		—					
37. A						—	—
38. G						—	
39. B	—						
40. H	—					—	—
41. B		—					
42. K		—					—
43. E						—	—
44. F		—					
45. C						—	—
46. G			—				
47. A						—	—
48. H		—					
49. B						—	
50. J						—	
51. A			—				
52. F						—	
53. D			—				
54. F	—						
55. D	—						
56. H					—		
57. B					—		
58. F						—	—
59. D					—		
60. F			—				

Combine the totals of these columns and put in the blank for PHM in the box below.

**\*Reporting Categories**

**PHM** = Preparing for Higher Math

N = Number & Quantity

A = Algebra

F = Functions

G = Geometry

S = Statistics & Probability

**IES** = Integrating Essential Skills

**MDL** = Modeling

Number Correct (Raw Score) for:	
Preparing for Higher Math (PHM) (N + A + F + G + S)	_____ (35)
Integrating Essential Skills (IES)	_____ (25)
Total Number Correct for Mathematics Test (PHM + IES)	_____ (60)
Modeling (MDL) (Not included in total number correct for mathematics test raw score)	_____ (20)

**Test 3: Reading—Scoring Key**

Key	Reporting Category*		
	KID	CS	IKI
1. C	___		
2. F	___		
3. C		___	
4. J	___		
5. D		___	
6. G		___	
7. A	___		
8. G			___
9. C			___
10. J			___
11. B	___		
12. F	___		
13. B	___		
14. J		___	
15. C	___		
16. F		___	
17. B	___		
18. F			___
19. D		___	
20. J	___		

Key	Reporting Category*		
	KID	CS	IKI
21. B		___	
22. J	___		
23. C	___		
24. J	___		
25. B	___		
26. G	___		
27. B	___		
28. J	___		
29. A		___	
30. F		___	
31. C	___		
32. G	___		
33. A	___		
34. J	___		
35. C	___		
36. G	___		
37. D			___
38. H		___	
39. C		___	
40. F	___		

**\*Reporting Categories**

**KID** = Key Ideas & Details

**CS** = Craft & Structure

**IKI** = Integration of Knowledge & Ideas

Number Correct (Raw Score) for:	
Key Ideas & Details (KID)	___ (24)
Craft & Structure (CS)	___ (11)
Integration of Knowledge & Ideas (IKI)	___ (5)
Total Number Correct for Reading Test (KID + CS + IKI)	___ (40)

**Test 4: Science—Scoring Key**

Key	Reporting Category*		
	IOD	SIN	EMI
1. C		___	
2. F			___
3. C	___		
4. F		___	
5. C		___	
6. F	___		
7. A			___
8. G	___		
9. A	___		
10. G			___
11. D		___	
12. F			___
13. B	___		
14. G	___		
15. B	___		
16. H			___
17. A	___		
18. H	___		
19. D	___		
20. F	___		

Key	Reporting Category*		
	IOD	SIN	EMI
21. B		___	
22. H		___	
23. B			___
24. F			___
25. D			___
26. J		___	
27. D	___		
28. F		___	
29. B	___		
30. G		___	
31. C		___	
32. F	___		
33. D	___		
34. G			___
35. C	___		
36. G			___
37. A			___
38. J	___		
39. D	___		
40. G	___		

**\*Reporting Categories**

**IOD** = Interpretation of Data

**SIN** = Scientific Investigation

**EMI** = Evaluation of Models,  
Inferences & Experimental Results

Number Correct (Raw Score) for:	
Interpretation of Data (IOD)	___ (19)
Scientific Investigation (SIN)	___ (10)
Evaluation of Models, Inferences & Experimental Results (EMI)	___ (11)
Total Number Correct for Science Test (IOD + SIN + EMI)	___ (40)

## Explanation of Procedures Used to Obtain Scale Scores from Raw Scores

On each of the four tests on which you marked any responses, the total number of correct responses yields a raw score. Use the table below to convert your raw scores to scale scores. For each test, locate and circle your raw score or the range of raw scores that includes it in the table below. Then, read across to either outside column of the table and circle the scale score that corresponds to that raw score. As you determine your scale scores, enter them in the blanks provided on the right. The highest possible scale score for each test is 36. The lowest possible scale score for any test on which you marked any responses is 1.

Next, compute the Composite score by averaging the four scale scores. To do this, add your four scale scores and divide the sum by 4. If the resulting number ends in a fraction, round it off to the nearest whole number. (Round down any fraction less than one-half; round up any fraction that is one-half or more.) Enter this number in the blank. This is your Composite score. The highest possible Composite score is 36. The lowest possible Composite score is 1.

ACT Test F11	Your Scale Score
English	_____
Mathematics	_____
Reading	_____
Science	_____
<b>Sum of scores</b> <span style="float: right;">_____</span>	
<b>Composite score (sum ÷ 4)</b> <span style="float: right;">_____</span>	

NOTE: If you left a test completely blank and marked no items, do not list a scale score for that test. If any test was completely blank, do not calculate a Composite score.

Scale Score	Raw Scores				Scale Score
	Test 1 English	Test 2 Mathematics	Test 3 Reading	Test 4 Science	
36	73-75	58-60	39-40	39-40	36
35	70-72	55-57	38	38	35
34	68-69	53-54	37	—	34
33	66-67	52	36	37	33
32	65	50-51	35	36	32
31	64	49	34	35	31
30	63	47-48	33	34	30
29	61-62	45-46	32	33	29
28	60	43-44	31	32	28
27	58-59	40-42	30	31	27
26	56-57	38-39	29	30	26
25	54-55	36-37	28	28-29	25
24	51-53	34-35	27	26-27	24
23	48-50	32-33	26	24-25	23
22	45-47	30-31	24-25	22-23	22
21	42-44	29	23	21	21
20	39-41	27-28	21-22	19-20	20
19	36-38	26	20	17-18	19
18	35	23-25	18-19	15-16	18
17	33-34	21-22	17	14	17
16	30-32	17-20	15-16	12-13	16
15	27-29	14-16	14	11	15
14	25-26	11-13	12-13	10	14
13	23-24	9-10	11	9	13
12	22	7-8	9-10	8	12
11	19-21	6	8	7	11
10	15-18	5	7	6	10
9	13-14	4	6	5	9
8	11-12	3	5	4	8
7	9-10	—	4	3	7
6	7-8	2	—	—	6
5	6	—	3	2	5
4	4-5	1	2	—	4
3	3	—	—	1	3
2	2	—	1	—	2
1	0-1	0	0	0	1





PO BOX 168  
IOWA CITY, IA 52243-0168